



Government of **Western Australia**
Department of **Health**
Licensing and Accreditation Regulatory Unit

Building Guidelines

For the construction, establishment
and maintenance of
Psychiatric Hostels

Licensing and Accreditation Regulatory Unit

Department of Health
189 Royal Street
East Perth WA 6004

Reprinted October 2017

Revised October 2011

First published September 1999

Copyright to this material is vested in the State of Western Australia unless otherwise indicated. Apart from any fair dealing for the purposes of private study, research, criticism or review, as permitted under the provisions of the *Copyright Act 1968*, no part may be reproduced or re-used for any purposes whatsoever without written permission of the State of Western Australia.

Table of contents

1.	Introduction	2
Part 1: Legal Considerations		7
2.	Guideline Compliance	8
Part 2: Design Philosophy		11
3.	Philosophical Approach	12
Part 3: Psychiatric Hostel Design Considerations		15
4.	Planning and Design of a Psychiatric Hostel	16
5.	Site	22
6.	Building Design	25
7.	Interior Design	41
Part 4: Technical Considerations Engineering Services		43
8.	Engineering Services	44
9.	Fire Safety Guidelines	51
Part 5: Group Home Design Considerations		52
10.	Planning and Design of Group Homes	53
11.	Site	55
12.	Group Home Construction	57
13.	Interior Design	62
14.	Engineering Services	63
15.	Fire Safety Guidelines For Group Homes	74
Part 6: Design Quality		75
16.	Facility Design Checklist	76
Appendix 1 – Approval to occupy inspection		79
Appendix 2 – Legionnaires’ Disease		92

1. Introduction

1.1 Overview

While many people suffering mental illness are able to reside at home, either on their own or with family, this is not a realistic option for all. For those that cannot manage that level of independence, other options are available. The Psychiatric Hostel system is one such option.

The system of Psychiatric Hostels came into being in Western Australia in the 1970s to accommodate people being discharged from State Government Psychiatric Hospitals.

Psychiatric Hostel accommodation caters for a very disadvantaged and vulnerable group within the community. Features of this community group include:

- chronic and severe mental illness
- take considerable quantities of psychotropic drugs
- inability to manage living independently in the community
- managed by local mental health team, Hostel team or General Practitioner
- very limited family involvement
- require 24 hour support and assistance with a range of daily activities.

Psychiatric Hostel accommodation is defined under *The Private Hospitals and Health Services Act 1927*, Part IIIB, Section 26P as:

“Private premises in which 3 or more persons who;

- a) are socially dependant because of mental illness; and**
- b) are not members of the family of the proprietor of the premises, reside and are treated and cared for.”**

For the purpose of these guidelines a Psychiatric Hostel is defined as a residential building providing accommodation for people suffering mental illness who need assistance with daily living and/or personal care who for a variety of reasons are unable to remain in their own home, who for a variety of reasons are unable to remain in their own homes.

In broad terms Psychiatric Hostels fall into two classifications:

- Hostels and
- Group homes.

Hostels tend to be larger establishments and accommodate individuals who have a greater degree of chronicity.

Group homes are smaller residential establishments and accommodate individuals with a greater degree of independence. The group home may also have a rehabilitation function.

1.2 General

The guidelines are intended to generate discussion leading to further development and to foster innovation and/or alternative approaches rather than hinder them.

The facility design philosophy is variable within a 'home-like' framework. This attempt to create a residential 'home-like' environment in a Psychiatric Hostel is part of the process called 'normalisation' (refer to Section 3.2 – Normalisation). Mandatory elements are those that relate to safety and the services to be provided for the resident.

To ensure the success of the Psychiatric Hostel, consideration shall be given to the way the Psychiatric Hostel is to be run including:

- staffing levels in accordance with State expectations
- the philosophy of the operating organisation.

Early consultation with Licensing and Accreditation Regulatory Unit (LARU) during the design process is highly recommended to resolve any design problems at the outset.

1.3 Use of this Document

The formatting of this document is designed to assist the user. The document has been organised into parts and sections for ease of use by architects and consultants, as well as by licensees and managers of Psychiatric Hostels.

The following notes should assist the reader:

- Text presented in a shaded box provides the central and most important design objective for a particular issue.
- Bold text (other than headings) identifies highly important or mandatory requirements.

Shall and Should

In this document the word 'shall' means mandatory and the word 'should' means recommended.

1.4 Glossary

AS – Australian Standard.

BCA – Building Code of Australia (current edition with amendments) which form part of the National Construction Code, (NCC) and incorporates all minimum on-site construction requirements.

BGA – Break glass alarm.

Central Facility – The central facility should contain services such as administration, main meeting room, the central kitchen and/or laundry, etc. This should be separated from the residential facilities.

DFES – Department of Fire & Emergency Services of Western Australia

Director General – Director General of Health, Department of Health (Western Australia).

Disabled facility – A disabled facility contains toilet, hand basin and grip bars and is suitable for independent wheel chair use, refer AS 1428.1 – Design for access and mobility.

DOH – Department of Health (Western Australia).

EWIS – Early Warning Intercom System.

Fully Assisted Facility – A fully assisted bathroom/toilet provides grip bars, bathing/toileting and hand washing facilities and is large enough to allow either one or two staff members assisting residents.

FRL – Fire Resistance Level (as required by the Building Code of Australia).

Home-like environment – The Private Psychiatric Hostel should create an environment that is as near to residential as possible.

LARU – Licensing and Accreditation Regulatory Unit.

NCC – National Construction Code is a set of codes to enable the achievement of a nationally consistent, minimum standards of relevant safety (including structural safety and safety from fire), health, amenity and sustainability objectives efficiently.

Normalisation (Social Role Valorisation) – Normalisation supports the use of culturally acceptable and valued means to enable people who are devalued by society to achieve and maintain valued social roles.

Partially Assisted Facility – A partially assisted bathroom/toilet provides grip bars, bathing/toileting and hand washing facilities and is large enough to allow one staff member to assist the resident.

Private Psychiatric Hostel – For the purpose of these guidelines Psychiatric Hostel shall mean Private Psychiatric Hostel.

PHBG – means Psychiatric Hostel Building Guidelines.

RCD – Residual Current Device.

Residential Facility – Each residential facility should be treated as a single ‘house’ form, and read as such from the street. It should provide the facilities of a typical home with modifications to provide the necessary enabling environment.

RWP – Rain water pipe.

‘shall’ – means mandatory.

‘should’ – means recommended.

WAHFG’ – means the “Western Australia Health Facility Guidelines for Engineering Services”.

1.5 Glossary of Referenced Australian Standards

Within the Psychiatric Hostel Building Guidelines certain Australian Standards are referenced by number. Where the whole Australian Standard is not applicable, only the relevant part has been referenced within the text, for example AS 1428.1. All the Australian Standards noted within the text are listed below. To assist the reader, where a section or part of a standard is referenced the primary title is also listed here (in italics).

This list is not an exhaustive list of Australian Standards by any means, and should not be taken to mean that only these standards apply to the building or upgrading of a Psychiatric Hostel. Those involved in any Psychiatric Hostel project, should consult the National Construction Code (NCC) (current edition) and the “Catalogue of Australian standards and Other Products” (current edition), to determine if there is an applicable Australian Standard for the work under consideration.

For additional information relating to standards and codes, the reader is directed to section 2.7 of the Psychiatric Hostel Building Guidelines, “Standards and Codes”.

Standard	Title
AS 1158	The lighting of urban roads and other public thoroughfares.
AS 1158.1	Performance and installation design requirements.
AS 1288	Glass in buildings – Selection and installation.
AS 1324	Air filters for use in general ventilation and air-conditioning
AS 1324.2	Methods of test.
AS 1345	Identification of contents of pipes, conduits and ducts.
AS 1428	Design for access and mobility.
AS 1428.1	General requirements for access – Buildings.
AS 1428.2	Enhanced and additional requirements – Buildings and Facilities
AS 1428.4	Means to assist the orientation of people with vision impairment – Tactile Ground Surface Indicators
AS 1530	Methods for fire tests on building materials, components and structures.
AS 1530.2	Test for flammability of materials.
AS 1530.3	Simultaneous determination of ignitability, flame propagation, heat release and smoke release.
AS 1668	The use of mechanical ventilation and air-conditioning in buildings.
AS 1668.1	Fire and smoke control.
AS 1668.2	Mechanical ventilation for acceptable indoor air quality.

Standard	Title
AS 1670	Automatic fire detection and alarm systems – System design, installation and commissioning.
AS 1680	Interior Lighting.
AS 1680.1	General principles and recommendations.
AS 1680.2.0	Recommendations for specific tasks and interiors.
AS 1905	Components for the protection of openings in fire-resistance walls.
AS 1905.1	Fire-resistant doorsets.
AS/NZS 2208	Safety glazing materials in buildings.
AS/NZS 2293	Emergency evacuation lighting for buildings.
AS 2485	Water supply – Backflow prevention devices.
AS 3000	Electrical installations – Buildings, structures and premises (known as the SAA Wiring Rules).
AS 3003	Electrical installations – patient treatment areas of hospitals and medical and dental practices.
AS 3008	Electrical installations – Selection of cables.
AS 3008.1	Cables for alternating voltages up to and including 0.6/1 kV
AS 3009	Electrical installations – Emergency power supplies in hospitals
AS 3439	Low voltage switchgear and controlgear assemblies.
AS 3439.1	Type-tested and partially type-tested assemblies
AS 3500	National Plumbing and Drainage Code.
AS/NZS 3666	Air-handling and water systems of buildings – Microbial control.
AS 4146	Laundry practice.
AS 4254	Ductwork for air-handling systems in buildings.

Part 1:

Legal Considerations

2. Guideline Compliance

2.1 *Private Hospitals and Health Services Act 1927*

Psychiatric Hostels are licensed and regulated under the *Private Hospitals and Health Services Act 1927*. Under section 26J, the Act empowers the Director General of Health to license Psychiatric Hostels and issue guidelines with respect to their construction, establishment and maintenance.

2.2 Psychiatric Hostels Guidelines Application

These guidelines apply to new facilities; an existing facility if altered, or any building or renovation works; if there is a change of function; if there is a written complaint regarding the premises; and or change of ownership. Contact LARU to clarify the licensing process.

2.3 Compliance

Compliance with these guidelines is a specific condition of being granted a licence by the Director General to operate premises as a Psychiatric Hostel. Failure to comply with the guidelines will result in a breach of condition of licence.

It should be noted that under section 26K (1c) of the Act, no person may build, alter or extend any Psychiatric Hostel unless the Director General has approved of the building, alteration or extension as the case may be.

Any applicant requesting a licence shall be required to submit for approval any site plans, plans, specification, and any other documentation which LARU may determine necessary, to evaluate compliance with the guidelines. Approval will be issued in writing and may be conditional.

It is emphasised that compliance with these guidelines forms only one element of the Psychiatric Hostel licensing process. Conformity with other service planning criteria and relevant regulations is essential. It is assumed that other facets of the overall service planning process have already been finalised or are proceeding concurrently.

Compliance with these guidelines alone cannot be construed as an approval for proceeding with any development.

Formal written notification from the Director General or his/her nominated representative must be received prior to commencement of service.

2.3.1 Modernisation compliance

Where it can be demonstrated that total compliance is impractical or impossible within structural and spatial limitations, dispensations, may be considered. However, this cannot be construed to mean that the granting of an dispensation is guaranteed, particularly where major improvements required for resident safety are in question.

Where it is proposed that a portion of an existing building be substantially redeveloped, the design shall comply with these guidelines as far as is practical within structural and spatial limitations.

2.3.2 Partial modernisation compliance

Concessions are possible where existing buildings are being modified. The final outcome shall be a result of negotiation with LARU and as approved by LARU.

When it is not financially viable to modernise the entire facility in accordance with these guidelines, LARU may give approval for the renovation of certain areas of the facility only. The approval would be conditional upon the incorporation of the appropriate measures or features that would guarantee the safety and security of residents and staff, as well as access by the disabled and the effective operation of the facility.

The Director General may also make it conditional that the outstanding items be resolved progressively, as finances become available. A time frame might also be imposed.

When partially modernising a facility, fire barriers shall physically separate those areas that do not comply with these guidelines (in particular, Section 9 – Fire Safety), from modernised areas.

Fire barriers must be of not less than 120/120/120 FRL (fire resistance level), extending through the full height of the building. Doors in these barriers shall also be 2-hour fire rated.

2.3.3 Extension compliance

New additions to any Psychiatric Hostel facility shall conform to these guidelines.

2.4 The Right of Appeal

An applicant has the right of appeal.

When the Director General refuses to license or re-license a facility, due to an applicant's serious non-compliance with the guidelines, as interpreted by the Director General, the applicant may, under the *Private Hospitals and Health Services Act 1927*, lodge an appeal with the Director General of the refusal being formally notified, i.e. date of issue of the letter.

2.5 Equivalent Design Alternatives.

The primary objective of the guidelines is to achieve a desired performance, result or service. Prescriptive limitations, such as exact minimum dimensions or quantities, describe a condition commonly recognised as a practical standard for normal operation. For example, the reference to minimum room area is understood as being the amount of room needed for resident and staff activities and the placement of furnishings. This avoids the requirement for complex descriptions of procedures for appropriate functional planning. However detailed planning of the various areas is most important. Consulting with the management, staff, LARU and where possible the residents and their relatives should form part of the detailed planning process.

Where specific measurements, capacities or other standards are described, equivalent alternative solutions will be assessed. These may be deemed acceptable if the intent of the standards has been met.

It is important to note that the design principles contained in these guidelines should not be construed as a restriction to design innovation. Within the homelike framework, innovation that improves the living environment for residents and the effectiveness of staff is encouraged.

2.6 Statutory Authority Approval

The approval by the Director General to create or continue to operate a Psychiatric Hostel under the *Private Hospitals and Health Services Act 1927*, does not exempt the owner, architect or builder from the necessity to comply with any statutory requirements established and controlled by other authorities. For example, the requirements of:

- Alinta Gas
- Building Code of Australia National Construction Code
- Disability Services Commission
- Local Authority
- Water Corporation
- Western Power
- Worksafe WA.

2.7 Standards and Codes

Codes, rules, standards, specifications, etc., of statutory organisations, or those specifically referred to in the text of this document, shall be deemed to be specific requirements of these guidelines. Standards Australia publications are referenced where appropriate. A glossary of the Australian Standards used within the Psychiatric Hostel Building Guidelines is detailed under section 1.5 – Glossary of Referenced Australian Standards.

Exclusions and special conditions applied to said codes, rules, standards and specifications by the Building Code of Australia National Construction Code, shall also apply.

2.7.1 Reference to Standards

Where a code or standard is listed or referred to within these guidelines and is not dated, the appropriate document shall be the latest edition of that code or standard, and shall incorporate all revisions. Where a completely different code or standard has replaced the referenced code or standard, LARU shall be consulted to ascertain its relevance and acceptability.

2.7.2 Difference between ‘Guidelines’ and ‘Codes and Standards’

Where a difference occurs between the requirements of these guidelines and the relevant codes and standards, then the requirements of these guidelines shall be construed as being the preferred requirement.

2.7.3 Omitted relevant Australian Standards

Where Standards Australia documents exist which are specifically applicable to the requirements of Psychiatric Hostel construction, equipment, service, and practice, but are not referred to in these guidelines, they should be adopted as being indicative of ‘good practice’.

Part 2:

Design Philosophy

3. Philosophical Approach

3.1 General

The aim is to create a Psychiatric Hostel environment that is as near to residential as possible. The specific needs of the target population should be recognised.

Naturally, the preferred residential facility for those with a mental illness is his or her own home, but until appropriate support networks and services are in place, many people suffering from mental illness will require the services of the quasi-institutional model. The opportunity to choose between different types of housing options must always be available. There will be a need for home-like Psychiatric Hostels for some time to come.

3.2 Normalisation

Normalisation should be the goal of organisations when considering the character, image and operation of a Psychiatric Hostel.

The concept of normalisation (or Social Role Valorisation) challenges the negative roles and aspects of institutions. Normalisation supports the use of culturally acceptable and valued means to enable people who are devalued by society to achieve and maintain valued social roles.

The aim is to maximise independence, capabilities and individuality of each resident. Psychosocial and physical support should encourage residents to operate to their maximum potential (refer Section 3.3 – Enabling Model).

Implementation of the theory and principles of normalisation should be reflected in the Psychiatric Hostel design. Although a 'normalised' setting may not be exactly the same as a typical home, its internal spaces and furnishing should convey the message to the residents, relatives, friends and the community, that the residents are deserving, competent and valued people, who are a valued part of the community.

3.3 Enabling Model

A person living at home, with a disability or chronic illness that significantly impairs functioning, and without personal and social support, will obviously experience stress with its consequent problems.

The common solution has been to react to the individual's crisis by placement in a Psychiatric Hostel, or other institutional setting. In many of these places resident's needs are catered for in an over-compensatory manner that sets up a form of stressful dependency.

This situation can be as negative in its effect on the individual as the stress condition. It tends to remove independence, decision making and choices from the individual.

The Enabling Model

The goal is to achieve an environment that is suitable to the individual level of adaptability. Sufficient and subtle support should be provided to enable the individual to function at the highest level of independence. Challenges to improve and achieve, and an opportunity to control one's own life should also be incorporated.

3.4 Philosophical Principles

During the development of a Psychiatric Hostel, there are two distinct sets of philosophical guidelines that shall be considered.

National Standards for Mental Health have a focus on the rights of consumers (residents) and the involvement of consumers in their own care. The guiding principles of these standards should be incorporated in the design.

3.4.1 National Standards for Mental Health Services

For current information on the National Standards for Mental Health Services refer to the Australian Government, Department of Health and Aging.

3.4.2 The Hostel Building Guidelines

It is essential to consider the operating philosophy and programme prior to the consideration of the architectural design. The key principles are:

1. In the Psychiatric Hostel, residents should be regarded with respect, to enable them to establish and/or maintain their valued social roles.
2. The physical environment for the Psychiatric Hostel resident should, as far as possible, be of a domestic scale and detailing, enabling residents to relate to a familiar setting.
3. The physical environment and the management program should encourage and foster individuality and enable the resident to maintain and/or develop his or her identity by having access to a normal set of choices.
4. Essential supports must be incorporated in a subtle (and not over-obvious) manner. The design must reduce hazards while inducing a feeling of competence and confidence in the resident. It must maximise the residual abilities of the residents and not over-emphasise their disabilities.
5. Environmental competence involves an understanding of the relationship between environmental support provided and the individual's capabilities, adaptive behaviour and adaptive range.
6. Management objectives and architectural design response must directly relate to the physical, social and psychological needs of the residents and staff.

This principle includes the consideration of:

- independence
- options and choice
- continuation of roles and lifestyles
- social interaction
- community outreach
- personal space and private territory
- privacy
- minimal institutional characteristics
- security
- meals
- orientation and mobility
- safety.

Part 3:

Psychiatric Hostel Design Considerations

4. Planning and Design of a Psychiatric Hostel

4.1 General

The guidelines represent minimum standards and at the same time seek to encourage Psychiatric Hostel design innovation within the 'home-like' framework (refer Section – 2.5 Equivalent Design Alternatives).

4.2 Achieving appropriate outcomes

To achieve the desired design outcome it is recommended that the following are taken into consideration:

- Experienced professional consultants (architects, engineers, interior designers, etc.) should be commissioned.
- Staff, residents and visitors should be consulted about their needs and priorities.
- On-going negotiation and discussion with LARU shall occur.

4.3 Design Principles

The design of the facility should take into consideration the specific needs of residents, particularly the need for personal space and areas for quiet reflection.

In the design of the Psychiatric Hostel, the following issues should be carefully resolved:

4.3.1 Security

Security issues that should be considered include:

- Entry and exit control to the facility and to resident bedrooms.
- Medication storage, in a central location or in resident bedrooms, must be secure.
- Appropriate unobtrusive external fencing will enhance the sense of security provided to the residents.

4.3.2 Impact on others

Site location should be considered in relation to street exposure and the impact on neighbours, in particular the audible impact on other Psychiatric Hostel residents and neighbours. The visual impact of anti-social activities should also be considered. This does not mean high solid fences to visually isolate, but thoughtful solutions to ensure the rights of both residents and the public are addressed.

4.3.3 Appropriate location of controls

Consideration should be given to the control of air conditioners/ evaporative coolers, ceiling fans and other appliances in resident areas, to enhance the resident's control of their environment. In common areas of the Psychiatric Hostel, control of these functions may best be delivered from a staff controlled area.

4.4 Smoke Free Environment

The right to a smoke free environment within the Psychiatric Hostel is to be guaranteed. However consideration should be given to the needs of residents, staff and visitors who smoke, i.e. provision of an appropriate smoking area. The design of the smoking area shall be consistent with current legislation related to smoking in the workplace and enclosed public areas.

4.5 Occupational Health

The occupational health, safety and welfare of staff shall be considered in the design of a Psychiatric Hostel. Current WorkSafe practices and legislation shall be adopted.

4.6 Infection Control

All areas of the facility shall be designed, constructed, furnished and equipped in keeping with the principles of infection control.

Infection control involves the prevention of possible spread of infection by the minimisation of transfer of micro-organisms from person to person.

A number of strategies contribute to the control of infection, such as hand washing, careful aseptic technique and the observance of “universal precautions” (Standard and Additional Infection Control Precautions).

By far the most important of the infection control strategies is effective hand washing. Hand washing facilities shall be installed in all resident care areas, and also in all areas where careful attention to hygiene is essential, such as kitchens, laundries, utilities, etc. and staff amenities areas, such as bathrooms, toilets and change rooms. Hand basins for staff use shall be equipped with soap dispensers, hand drying facilities and lever action taps to allow hands free operation.

Hand basins in kitchens shall be equipped with foot or electronically operated taps, to allow totally hands free operation.

Consideration shall be given to the size of the hand basin, ensuring the size will enable hand washing to occur. Basins with overflow outlets shall not be provided in areas where infection control is critical, that is kitchen and consulting rooms.

4.7 Safety

All detailing within the Psychiatric Hostel shall consider the special needs of a client group who, from time to time, may display high levels of expressed emotion. This may be manifested in the form of random acts of aggression, either self directed (in the form of self-harming behaviour) or directed at the facility. The design of the Psychiatric Hostel should reflect this possibility in its design and fit out.

4.8 Design of a New Psychiatric Hostel

The design of a new Psychiatric Hostel involves the creation of ‘home-like’ residential facilities linked to a non-residential, central facilities building. These are referred to as the ‘Residential Facilities’ and ‘Central Facility’ in these guidelines.

4.8.1 General

The configuration of the residential facility and the linkages to the central administration services should give consideration to the particular resident requirements, the operational philosophy, staffing levels and projected operational costings.

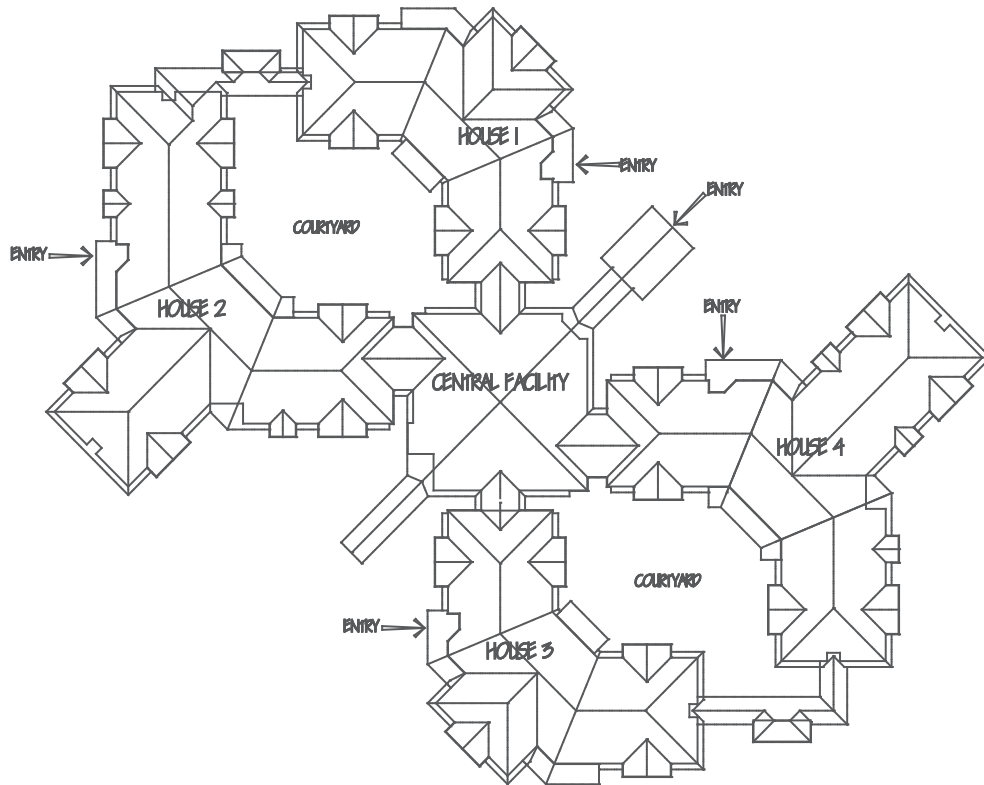

An example of a home-like psychiatric hostel.

Consideration should be given to breaking the residential facility into two or three smaller resident modules. It is recommended that the individual resident modules accommodate no more than ten residents. The living and service areas within the residence can then be located at the centre of the modules.

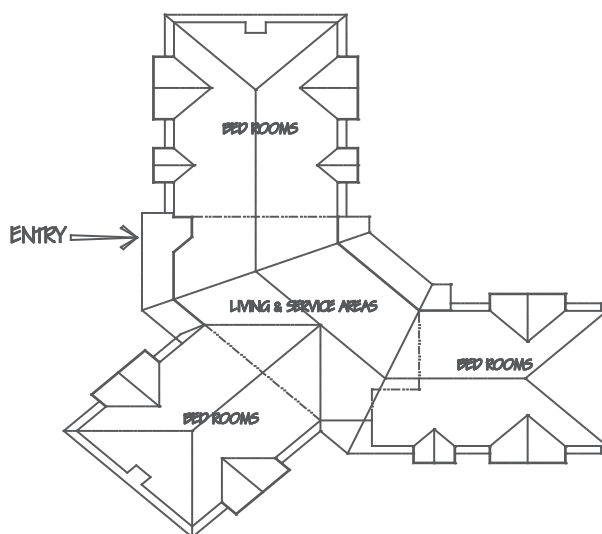

Arrangement of an individual resident module

The links between the residential and the central facility should be secure and weather proof. The links may include access to facilities that can be shared between residential facilities (e.g. Bathroom, activity spaces or additional storeroom). The link should connect into the living/service area or a passage servicing those spaces.

Each residential facility should be treated as a single 'house' form. It should have a separate entry treated as a front door, accessible from the street. Visitors should be encouraged to use the separate 'home' entry points rather than be channelled through a reception point. Vehicular and pedestrian access, and car parking at the house entry points, should also be incorporated. The multiple entry principle should not compromise the safety and security of the residents.

The architectural style should be sympathetic to the streetscape or adjacent buildings. Refer to Section 5 – Site, Section 6 – Building Design and Section 7 – Interior design for further architectural requirements.

4.8.2 Access and use

Psychiatric Hostel buildings, services and equipment shall be designed and constructed in accordance with the requirements outlined in the National Construction Code. The reference classification is Class 3 for Hostels, although other sections may also be appropriate.

Buildings and parts of buildings that are required to be accessible shall comply with the NCC – Part D3.1 General building access requirements. (Table 3.1).

In summary:

- Disabled access is required from the pedestrian entrance to and within not less than one type of each type of space that is for communal use by the resident.
- The number of accessible bedrooms (referred to as sole-occupancy unit in the NCC) to be provided for use by residents with disabilities shall meet the minimum requirements tabled in the NCC
- If a disabled bedroom is in a residential facility, then all shared areas of that residential facility eg laundry, tea prep area, dining, lounge areas etc shall be designed to be accessible in compliance with AS1428.1. and AS1428.2.

If more than 1 disabled bedroom is required in the hostel development, then these may be grouped together in the same residential facility.

Disabled parkings shall be provided in as required by the NCC and designed in accordance with AS1428.1.

4.9 Modernisation and extension of an existing facility

Although a residential scale and separation of the residential facility from the central facility is easier to create in a new building, the philosophy can be applied when modernising and extending an existing Psychiatric Hostel. An entire residential wing should be redeveloped or modified as a residential facility.

Requests for modernisation, partial modernisation and extension shall be submitted in writing to LARU for approval.

Approval will be issued in writing (refer to Section 2 – Guideline Compliance).

4.9.1 General

Traditional Psychiatric Hostel models have large central Lounge/Dining rooms. Residential facilities that include domestic scaled living rooms promote a more homely environment. The modernisation of an existing facility should include the provision of a range of sitting spaces and alternative living/dining room areas.

When remodelling central shared shower and toilet areas, the original open plan and impersonal design can be replaced with separate rooms containing a shower, toilet and hand basin ('ensuite'). Even refurbishment can have a dramatic effect on the building environment. Roof-lights can be installed to improve internal natural lighting levels (refer to Section 6.1 – Residential Facilities).

4.9.2 Practical aspects of modernisation

It should be noted that concessions are possible where existing spaces are involved.

Newly created bedrooms shall comply with current minimum sizes.

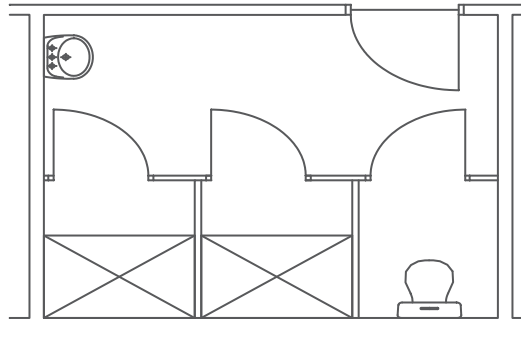

BEFORE

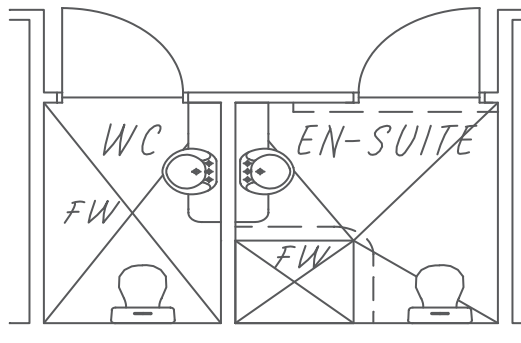

AFTER

Bathroom Modernisation

Where existing facility modernisation or replacement work is proposed all new work and/or additions shall comply, as far as practical, with these guidelines and any other codes, standards, regulations or legislation empowered by them.

Projects involving alterations and/or additions to existing buildings shall be programmed and phased to minimise disruption of retained existing functions.

Access exits and fire protection shall be so maintained that occupants' safety will not be jeopardised during construction.

5. Site

5.1 Location

The site selected for the Psychiatric Hostel should facilitate community access and promote residents' independence and quality of life.

The proposed development should be compatible with the current and future land use and zoning. The site should enable the Psychiatric Hostel to blend with the local environment and to become a desirable place to live.

The location should enhance community service delivery. A range of services should be accessible for the benefit of the resident, their relatives, visitors and staff. These should include public transport, pharmacy, banking, dentist, hospital, department store, and library.

5.2 Site planning

Site planning requires consideration of the needs of the users, the impact on neighbours and the presence of the facility within the community. Site planning also includes consideration of roadways, car parking, walkways, outdoor access, gardens, servicing and signage.

5.2.1 Needs of users

When the general suitability of the site for a Psychiatric Hostel has been assessed, consideration should be given to detailed site planning with a focus on the needs of users (i.e. residents, staff, visitors and suppliers).

In considering the site, features such as topography, views, vegetation, drainage, access, orientation and micro-climate should be assessed and positive features incorporated into the design. Well-considered site planning can contribute to personal safety, property security, energy efficiency and water conservation.

Careful site planning can significantly enhance the living environment for the future users of the Psychiatric Hostel.

5.2.2 Impact on neighbours

The interface between the Psychiatric Hostel and neighbouring areas should also be carefully considered. Privacy for neighbours and Psychiatric Hostel residents should be developed through careful placement of windows, fences and planting.

Pedestrian and vehicle access to the site shall be incorporated. Visual links to views or features of significance shall be considered.

If a site abuts or has view to a public open space or road with activity, then the site layout and building design should take these factors into account.

Neighbouring areas may expose the site to detrimental impacts (e.g. excessive traffic noise). These impacts shall be minimised to improve the environment for all users.

5.2.3 Community

Consideration should be given to the image the Psychiatric Hostel projects within the community. The image should demonstrate that residents are valued people. The Psychiatric Hostel should blend into the neighbouring environment and it should present a domestic residential appearance. The Psychiatric Hostel should fit within the surrounding neighbourhood's character.

5.2.4 Car parking

Car parking should be discretely located and should not dominate views. Sufficient car parking needs to be provided to satisfy applicable local authority requirements and the needs of staff and visitors. Parking should be dispersed around the site and associated with the entries to residential facilities. Transport arrangements for off-site travel should be considered. A covered drop-off point near the front door should be considered, e.g. carport.

5.2.5 Roadways

Roadways should be carefully planned to provide access for staff and visitors and for servicing and access for emergency vehicles to the Psychiatric Hostel. The location of internal roadways should be carefully considered in relation to bedrooms. The impact of internal roadways should be softened by using unit paving and planting trees and shrubs that, when grown, form a shade canopy.

Off-street car parking to comply with AS/NZS 2890.1 and AS/NZS 2890.6 – Off Street Car Parking.

5.2.6 Outdoor access and gardens

The Psychiatric Hostel shall provide access to useable external spaces, incorporating disabled access. The external spaces should include pathways, fixed and moveable seating in sheltered and exposed locations, barbecues and pergolas. Landscaping, both hard and soft, should provide as home-like an environment as possible.

Particular attention needs to be paid to the provision of adequate structured shade.

Plant types should be selected to provide a variety of colours during the year. Deciduous trees should also be incorporated as they provide an indication of the change in seasons.

Garden areas shall not incorporate toxic plants.

Adequate water service shall be provided for garden maintenance and for fire control purposes.

Outdoor areas should also have garden/security lighting to illuminate pathways and entrance areas.

External areas should take advantage of views and provide both a private backyard and a semi-public front garden. Visiting family and friends should also have access to these areas, as invited by the residents. External courtyard security is to be provided where appropriate (e.g. open tubular fencing). Continuous high solid walling with no visual relief is inappropriate.

5.2.7 Ramps

Where ramps are required for resident access or egress, minimum gradients, kerbs and handrails are to comply with the Building Code of Australia and AS 1428.1. Ramps in other areas, e.g. service roadways, shall comply with good design practice and be suitable for the task. Australian Standards, wherever applicable, shall be used.

Specific requirements of the St John Ambulance Association in relation to ramp gradients and ambulance park/loading area gradients should be noted.

St John Ambulance should be contacted to confirm current requirements.

5.2.8 Signage

Discreet external signage may be provided, however this should not detract from the home-like qualities of the Psychiatric Hostel.

5.2.9 Mail delivery

It is desirable for each residential facility to have its own street frontage and letterbox in addition to the mailbox for the administration facility. Discussions should be held with Australia Post to ensure that the installation of mailboxes meets with their approval.

6. Building Design

6.1 Residential facilities

Each residential facility should be treated as a single 'house' form. It should provide the facilities of a typical home with modifications to provide the necessary enabling environment.

Group Homes shall be designed and constructed in accordance with the requirements of the National Construction Code. The reference classification is Class 1B.

6.1.1 Entry and covered set-down

Each house should have a separate entry, preferably treated as a front door, accessible directly from the street. Visitors should not necessarily be channelled through a single reception point at the central facility but be encouraged to use the individual house entries.

Consideration should also be given to a covered set-down area associated with the entry. A carport with undercover access to the entry would be appropriate.

6.1.2 Bedrooms

To a large extent the bedroom will be the only personal space the resident has. Design features must recognise the right to privacy, security and personal space of the resident. Bedrooms may accommodate one or two residents, but single bedrooms are preferred.

At least 50% of the residents shall be accommodated in single bedrooms. The bedrooms shall be sized to provide space for the bed, sitting space for personal and social activities and space for staff attendance, if required.

The **minimum** size of a single bed resident room is **3300mm by 3600mm**. This size may need to be increased dependent upon position of door(s) and window features, furniture layout, extent of additional furniture (book cases, desks, TV), etc. A bedroom must not be used as a thoroughfare to rooms other than ensuite toilets, closets, bathrooms or dressing rooms that are for the exclusive use of the occupant(s) of that bedroom. They should not open directly into communal living areas, kitchen or other service areas. Bay windows are considered to be an advantage in that they provide additional useable floor space for sitting activities.

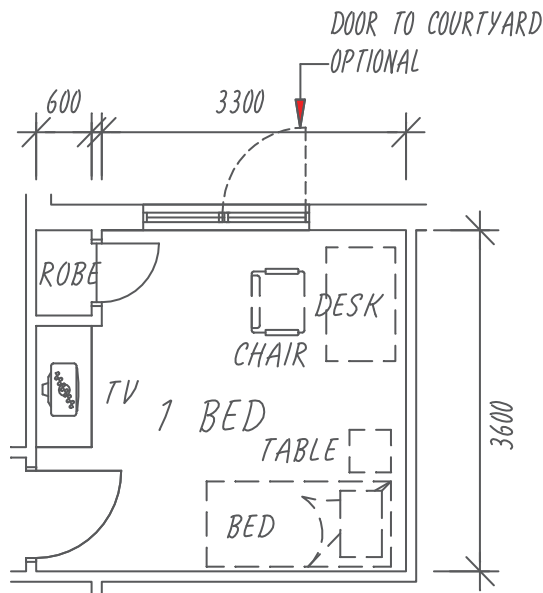

Example of a single bedroom

In the planning of all residents' rooms it is important to develop a detailed room layout showing:

- lighting and switch locations
- windows and doors
- heating and cooling equipment and controls
- furniture layout (bed, chairs, robe, bedside table, drawers, television and other possible personal furniture, etc.).

The **minimum** size of a two bed resident room is **3600mm by 6000m**. As for single bedrooms, the size may need to be altered dependent upon layout and fitout. In the case of the two-bed rooms, detailed consideration should be given to the room arrangement to provide maximum possible privacy for each resident and their visitors.

In designing the two bed room, it is important to develop a detailed room layout showing, in addition to those features listed above, the following:

- separate furnishings for each resident i.e., beds, robes, desks, chairs, television shelf, etc.
- Individual views to external spaces for each resident.

Bedrooms designed for more than two beds shall not be permitted.

It is also important to consider staff access to ensuites. The arrangements shall be such that each resident has easy access to his/her bed and personal belongings. Residents and their relatives should be encouraged to personalise the residents' room. Shelving for the display of personal items should be provided.

Accessible bedrooms for residents with disabilities shall be designed and furnished in accordance with AS1428.2 Design for Access and Mobility: Enhanced and additional requirements. The number of accessible bedrooms required in the psychiatric hostel shall be in accordance with the NCC – Table D3.1 Requirements for access with people with a disability.

6.1.3 Showers, toilets, basins and baths – generally

This section only describes **minimum** provision.

The retention of privacy and dignity is the most important aspect in the design of showering, toileting and bathing facilities in a Psychiatric Hostel.

The location of these facilities within the residential facility should promote privacy. The interior fitout should be as domestic as possible and should encourage residents to achieve their maximum level of independence.

The placement of showers, toilets and basins within the facility shall be considered. For the purposes of these guidelines, a room consisting of a shower, toilet and basin shall be known jointly as an ‘ensuite’.

Minimum Ensuite Requirements

Minimum provision shall be one ‘ensuite’ (shower, toilet, and basin) for every 4 residents. A dedicated ‘ensuite’ for each bedroom, with direct access from the bedroom, is preferred.

If there is a disabled bedroom in the residential facility refer to 6.1.2 – Bedrooms, than at least one accessible ensuite in accordance with AS1428.1 be provided. At least pan, one washbasin and one shower shall be accessible to residents with disabilities, within each residential facility.

Placement of the ‘ensuites’ shall take into account the need to limit to 15 metres the distance of travel from each bed to the nearest toilet. Ensuites should not be considered as “communal” facilities for general use of all residents (refer section 6.1.5.2 – Resident Communal Toilet).

Individual storage of personal toiletries in the ‘ensuite’ should be considered. Multi-compartment storage cabinets are considered appropriate for use in shared ‘ensuites’. Coat hooks should also be considered.

Acoustic privacy is important in shared facilities. Solid core doors fitted with acoustic seals shall be installed with acoustic air transfer ducts (not door grilles) for supply air.

Floor finishes shall be slip resistant in accordance with AS 4586 and falls sloped to wastes to prevent any ponding.

A bath (with assisted toilet and basin) shall also be provided within the facility for those who prefer bathing to showering. Refer Section 6.1.7 – Bathrooms, for design information.

Detailing and fit out of showers, toilets, basins and baths shall consider resident safety as referred to in section 4.4.

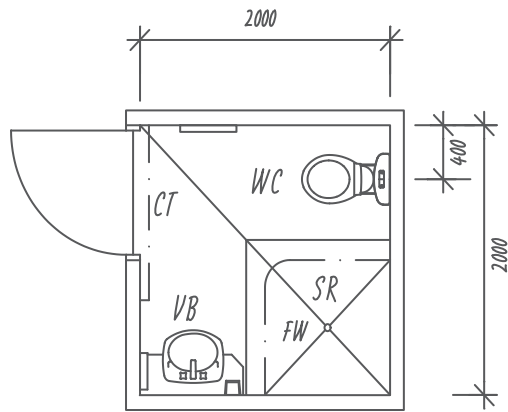

PLAN 1

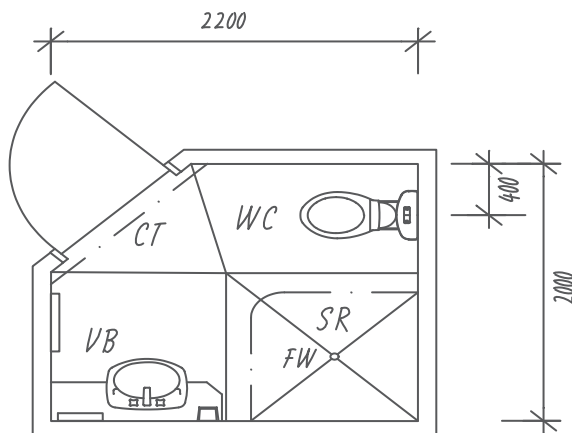

PLAN 2

Minimum ensuite requirement

6.1.4 Showers

Showers should have a design focus consistent with the requirements of AS 1428.1 be appropriately designed and sized with a minimum shower area of 1100 x 1100 recommended. Screens to contain water within the shower zone, access to taps without entering the shower into the shower zone.

The shower in the accessible ensuite shall comply with the requirements of AS1428.1.

Staff assistance within the shower rooms (with toilet and basin) is a design consideration.

6.1.5 Toilets

Toilet selection and installation

The room should have a design focus consistent with the requirements of AS 1428.1, although the toilet installation requires special consideration.

In particular the dimensions from the rear wall to the front of the pan, need to be considered. The distance from the front of the cistern to the front of the pan shall be approximately 600mm (720mm from rear wall to front of pan) and the top of seat approximately 460mm above the finished level.

Toilet seats for all residents toilets should be securely fixed, and be load rated to 150kg with lateral stability and fixings to comply with AS 1371.

Accessible toilets shall comply with AS1428.1.

6.1.5.1 Staff/Visitor's toilet

A toilet suitable for use by staff, visitors and disabled visitors shall be provided within each residential facility.

Where modules are directly connected centrally located facilities for visitors are considered adequate.

6.1.5.2 Resident communal toilet

A resident communal-use toilet (with hand basin) shall be provided near the activity/meals area.

A minimum of one toilet in the communal area shall be accessible. A unisex accessible toilet is acceptable and this accessible toilet may be used by disabled staff and/or visitors.

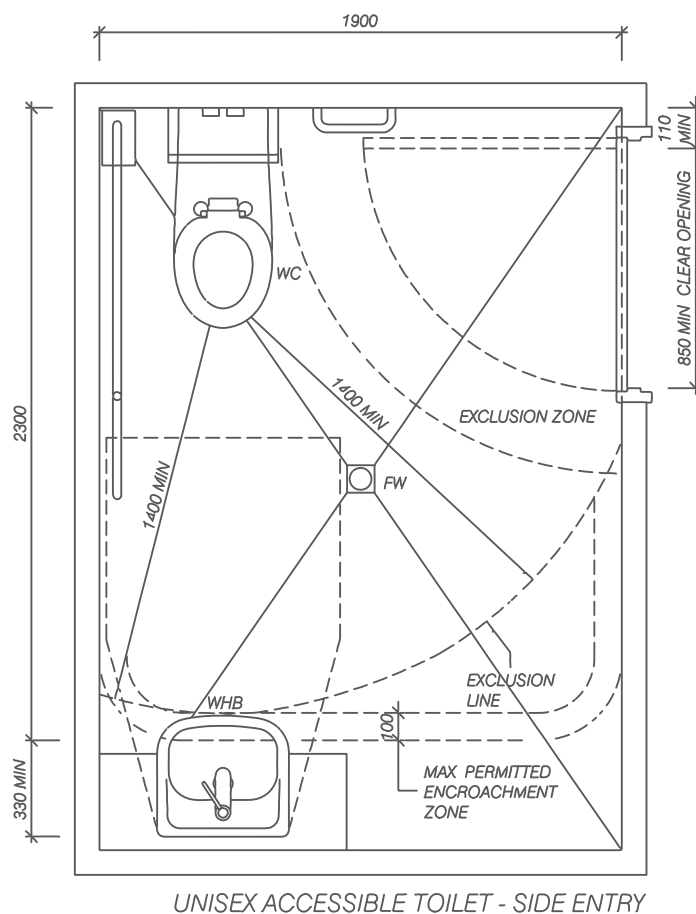

Communal toilet layout

6.1.6 Basins

Basins shall be appropriately sized to enable hand washing to occur, configuration according to AS 1428.1 is considered appropriate. Tapware should be chosen that is simple for residents to use (refer Section 6.1.9 – Plumbing Fittings).

Consideration shall be given to the size of the hand basin, ensuring the size will enable hand washing to occur. Basins with overflow outlets shall not be provided in areas where infection control is critical, that is kitchen and consulting rooms.

Mirrors over the basins are also required. The bottom of the mirror shall be no higher than 900mm to a height of not less than 1850mm above the plane of the floor. Mirrors shall be securely fitted and shall be of safety glass or other appropriate material resistant to excessive impact. A basin with a vanity unit should be incorporated as this enhances the residential quality of the bathroom.

Basins required in areas where infection control is critical, that is kitchen and consulting rooms, shall not be provided with plugs or overflow outlets, and there shall be no mirrors above the basins.

Hand washing facilities shall be securely anchored to withstand an applied vertical load of not less than 115kg on the front of the fixture.

The basins in accessible ensuites and accessible toilets shall comply with the requirements of AS1428.1.

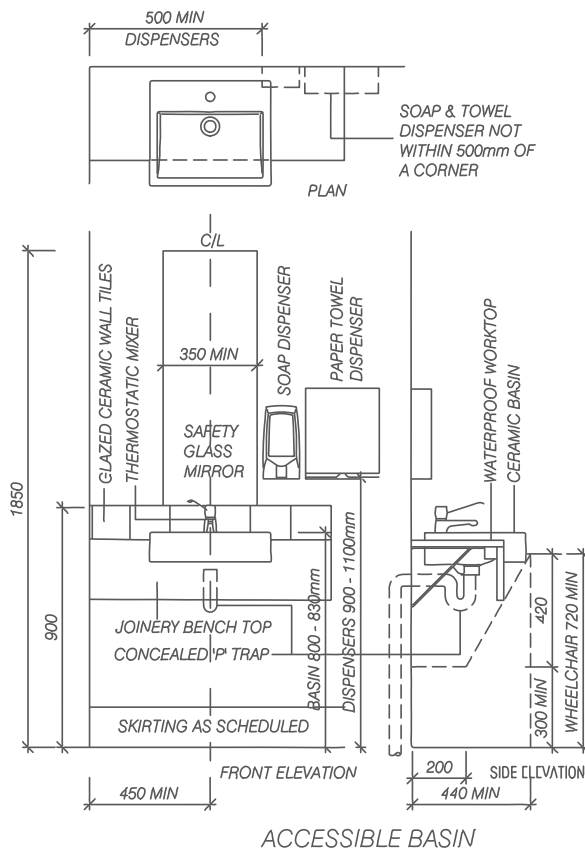

Basin configuration – resident use

6.1.6.1 Staff use hand basins

Each individual resident facility shall be provided with a hand basin for use by staff. The hand basin shall be equipped with lever action type taps, showing hot and cold markings, to allow for 'hands free' operation. Each basin shall also be provided with liquid soap and paper towel dispensers.

The size of the hand basin will enable hand washing to occur. Basins with overflow outlets shall not be provided.

6.1.7 Bathrooms

A separate room containing a bath shall be provided for residents who prefer bathing.

The bathroom may be centrally located to allow access to all residents. In a new building, a toilet shall be provided within the room to allow dignified toileting of residents during the bathing process. A hand basin shall also be provided. Consideration may also be given to providing a resident shower and if provided shall contain a toilet and hand basin within the room to allow for dignified toileting of residents. Consideration should be given to also include a resident shower in this room.

Where the residential facilities are directly connected, a minimum of one bathroom per 30 residents shall be provided. Replication may be necessary for stand-alone modules, but where they are directly connected, a single bathroom in a central location would suffice. Consideration must be given to the distances travelled by the resident, the right to privacy when going to the bathroom and the general accessibility of the central bathroom to all residents.

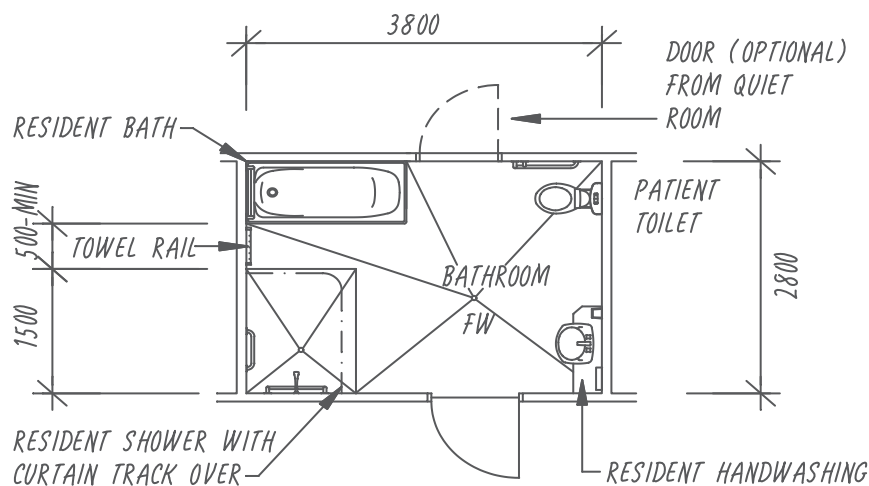

Bathroom layout – typical

6.1.8 Grip bars

Grip bars shall be detailed as described in AS 1428.1, except where otherwise noted in this document.

Grip bars, vertical adjustable shower supports, towel rails, soap holders, foot rests and any other fixture which may be used for support, shall have sufficient anchorage and strength to resist the sustained concentrated load of a falling heavy human.

6.1.9 Plumbing fittings

Location and arrangement of fittings for whatever purpose shall permit their proper use and operation.

Non-thermal transmitting handles are preferred with effective finger grips. Hot and cold indicators shall be very clear and the turning action should not require excessive force. Vandal proof style is recommended.

6.1.10 Lounge

A home-like lounge room shall be provided for each residential facility.

Lounge Rooms should be sized to provide comfortable seating and circulation space for the total number of residents and visitors expected to use it at any one time. The minimum lounge floor area shall be no less than 20 square metres. The total area of these sitting rooms shall consist of a minimum of two square metres of sitting space per resident. Corridors and verandas shall not be included in the minimum area requirements.

Selection of furniture will have an obvious impact on floor area. Indicative furniture layouts should be developed during the planning of the building (refer to Section 7 – Interior Design).

6.1.11 Quiet room

A quiet room shall be provided in each residential facility for reading, writing and quiet pursuits. It shall contain reading material and be appropriately furnished. The area of the quiet room shall be a minimum of 12 sq/m. A quiet room may also be used as overnight accommodation for relatives.

This overnight accommodation might consist of a couch/bed in the quiet room, a hand basin, shower and visitor's toilet nearby.

6.1.12 Family/Meals

A home-like family/meals room shall be provided for each residential facility. It shall be sized to provide space for normal residential type day activities (e.g. Meals, morning/afternoon tea, cooking, craft, games, etc.).

Selection of furniture will have an impact on floor area. Indicative furniture layouts should be developed during the planning of the building (refer to Section 7 – Interior Design).

Family and dining areas

The following areas shall be accommodated:

- Family: 2.8m² per resident (minimum of 20m² total)
- Dining: 1.5m² per resident (minimum of 16m² total).

6.1.13 Kitchen/Pantry/Tea preparation area (Residential unit)

Food service provision should be given early consideration. The operational arrangements and associated facility requirements need to be fully resolved prior to construction to facilitate a high quality food service.

A kitchen, pantry or tea preparation area shall be provided for each residential unit, depending on the facility type and food service policy.

The kitchen shall be capable of preparing or reconstituting main meals for the maximum number of occupants of the residential facility. The kitchen should include pantry provision, serving and clean up facilities. There may also be a small tea preparation area for use by residents and visitors.

Main meals prepared from a central production kitchen should be plated and served in the residential unit kitchen area to enable individual selection.

Visiting relatives or friends may also use the kitchen to prepare meals for individual residents. Adequate refrigeration and dry-goods storage within each house, and an oven sized to accommodate large containers (particularly where serviced from a central kitchen), shall be considered.

The kitchen/pantry should have direct access to the dining/meals area. It should also be designed for partial access by the disabled, at least for morning and afternoon tea preparation, e.g. pull out shelf or partially open under bench, lower height bench, etc.

The hot plate and oven should be electric, should have on/off lights for each hotplate and have front located controls. Staff controlled key isolators may also be considered.

Design of the kitchen/pantry area shall consider resident safety as referred to in section 4.4.

6.1.14 Sitting areas

Consideration should be given to the provision of alternative sitting areas, e.g. a corridor nook with views to the outside.

6.1.15 Smoke free environment.

The right to a smoke free environment within the Psychiatric Hostel is to be guaranteed. However, consideration should be given to the needs of residents and visitors who smoke, i.e. provision of an appropriate smoking area. The design of the smoking area shall be consistent with current legislation related to smoking in the workplace and enclosed public areas.

6.1.16 Dirty utility

A dirty utility room should be provided for each residential facility. Replication may be necessary if the facility layout requires long distances to be covered.

Facilities for pan sanitising should be considered. An electric or steam heated pan sanitiser is recommended for the safety of staff. A slophopper is required for initial disposal of pan/urinal contents before disinfection. The slophopper should be fitted with a flexible hand-spray nozzle (refer to section 8.5.2.3 – Back Flow Prevention). A stainless steel sink and drainer and a separate basin for staff hand washing should also be provided. Cupboards and/or racks should be provided for bedpan, bowl and urine bottle storage.

6.1.17 Dirty linen

A separate mechanically ventilated cupboard or storeroom shall be provided for the holding of dirty linen, prior to transfer to the laundry or a central holding area.

Containment of odours so that they do not disturb residents, staff and visitors is of utmost importance. Convenient pickup of the dirty linen for transfer to an off-site laundry, central holding area or on-site laundry should influence the final location of the dirty linen store, i.e. prevent crossing of resident areas with bags or trolleys of dirty linen.

6.1.18 Laundry (Residential)

A small laundry, for the washing of personal items, should be included as a separate room with convenient access to each residential facility. The laundry should provide space for a washing machine and clothes dryer and contain a trough, bench and space for an ironing board. External drying areas shall also be provided.

6.1.19 Storage

6.1.19.1 Clean linen store

A clean linen store shall be provided in each residential facility. The clean linen store can be either a storeroom or a storage cupboard.

Equipment store

It is important that careful analysis is made of the equipment requirements. Provision shall be made to accommodate equipment when not in use.

An equipment store shall be provided for the storage of items of equipment such as spare beds, furniture etc.

For some equipment, suitable out of the way parking areas within bathrooms is preferable, however other items require dedicated spaces.

6.1.19.2 Residents' store

Storage of seldom-used items belonging to residents should be accommodated in the resident's room.

6.1.19.3 Cleaner's store

A cleaner's store shall be provided in a location convenient to each residential facility. The cleaner's store shall have a cleaner's sink, a hand wash basin, (type C) room to accommodate a trolley and storage shelving and hanging racks. Mechanical ventilation shall be provided to the cleaner's store (refer to section 8.1.4 – Ventilation Rates).

6.1.19.4 Medication store/preparation

The storage of Schedule 4 and Schedule 8 drugs shall also be considered. Schedule 4 drugs are prescription drugs. Schedule 4R and Schedule 8 drugs are also prescription drugs and are drugs of addiction. They require additional security and dispensing control. Storage should be according to the *Medicine and Poisons Act 2014* and *Medicine and Poisons Regulation 2016* (as amended) or the relevant LARU standard.

In general, the storage of medications, dressings and surgical supplies is required to be in a locked cupboard in a locked room. Where the delivery of medication is by trolley, secure storage of the trolley must be considered.

6.1.20 Windows, screens and grilles

All rooms occupied by residents and staff on a regular basis shall have glazed windows or doors to achieve external views and/or make use of direct or borrowed natural light.

Resident bedrooms shall have windows overlooking external areas. An external area is a perimeter space around a building, a naturally ventilated and lit atrium or a courtyard.

Each external window and/or external glazed door panel area shall be not less than 10% of the floor area of the room concerned. An opening component equal to not less than 5% of the floor area of the same room should be provided. These requirements together will ensure natural light and ventilation in the event of an electrical or air handling system failure (refer Section 8.1 – Mechanical Services).

External windows shall be fitted with flyscreens and consideration should be given to the installation of security screens/grilles.

In addition windows shall have blinds and/or curtains. External shading devices should also be considered.

These measures should provide effective control of direct sunlight and glare from external sources. Windows are not to be obstructed by furniture, partitions, etc.

6.1.21 Doors

The minimum dimension of clear door openings to resident bedrooms/ corridors etc. in new areas shall be in accordance with NCC requirements.

All corridor doors shall swing in the direction of fire egress. Doors, except those to spaces such as ducts to which access is required infrequently, shall not swing into corridors in a manner that might obstruct traffic flow or reduce the required corridor width.

Glazed panels shall be provided in doors where observation for reasons of safety or security for residents and staff is required. Glazing in fire doors shall comply with the AS 1905.1.

Hardware shall be provided to suit the requirements of privacy, safety, security and function, e.g. indicator sets on toilets, showers, etc.

Rooms that contain baths, showers or toilets shall be equipped with door hardware that will permit emergency access from the outside.

As these rooms are generally only small in size, and particularly where door openings are narrow, the doors shall be capable of opening outwards or in a manner that negates the need to push against the resident who may have collapsed or secured themselves within the room.

All Psychiatric Hostels shall have a rational master key system. Locks shall be provided to staff rooms, drug stores, offices etc., as appropriate.

Door closers should be considered for doors that should remain closed, e.g. external doors, corridor doors, etc. Note that closers on doors can cause access problems for disabled people, and as such, their installation should be carefully considered and shall be compliant with AS1428.1 Design for Access and Mobility section 13.5 Door controls.

Door hold-open/closers should also be considered for doors that should remain open, e.g. doors on main traffic routes, delivery doors, etc. Free swing door closers may also be incorporated where appropriate.

Delayed action hold-open/closer may be considered where regular trolley movement by single operators might cause door damage, e.g. doors in corridors and into kitchens.

Security flyscreen doors where installed, shall not compromise emergency egress.

6.1.22 Corridors/Passageways

The corridors in the residential facilities shall be designed for disabled persons. A clear width (minimum) of 1200mm shall be provided.

Doors to rooms and/or spaces that are required to be accessed by persons with a disability shall comply with fig 31 of AS1428.1 "circulation spaces at doorways"

Emergency evacuation routes shall be provided in accordance with the NCC. Corridors shall be designed in short runs or have wall variation.

Where possible, natural light shall be allowed to penetrate into the internal corridor spaces via roof lights or internal window walls, e.g. glazing or glass blocks.

'Visual keys' or cues should also be considered when designing both the residential and the central facilities in the Psychiatric Hostel – e.g. different feature entry doors/porticoes/arches into each residential module.

6.2 Central facilities

In line with the philosophy of creating a more home-like environment, services such as administration, main meeting room, the central kitchen and/or laundry etc., shall be separated from residential facilities.

6.2.1 Enclosed walkways

The links between the central facility and residential facilities shall be enclosed and secure. The length of the walkways should be minimised to provide maximum staff efficiency. As a minimum the walkways shall provide shelter and security particularly for access at night. The walkways may incorporate rest spots, storage areas and facilities that are shared between the residential facilities, such as the bathroom.

6.2.2 Administration

A separate administration area should be provided in the Psychiatric Hostel. The administration area may include reception, waiting, manager's office, staff office and staff facilities, etc. A staff/visitors toilet may also be required. Consultation with staff as to their particular detailed requirements should be undertaken where possible.

6.2.3 Amenities room

A room for large functions should be provided. This room can be used for entertainment or events that involve residents.

6.2.4 Staff facilities

Staff facilities, e.g. shared lunch room, male and female change rooms, showers, toilets, etc. shall be provided, all in accordance with WorkSafe codes of practice and the Occupational Health Safety Act.

6.2.5 Service delivery point

A service delivery point shall be included for delivery to, and pickup from, service areas such as the central kitchen, laundry and storage areas.

6.2.6 Central laundry

If a facility for on-site laundering of linen is to be provided, then it shall comply with AS 4146 and be visually and acoustically isolated from the residential areas. Attachment to a central administration facility is acceptable.

Where the central laundry utilises gas appliances, an emergency gas isolation valve shall be installed in a location that is easily accessible during emergency egress.

If laundering is to be handled off-site, then a holding/pickup/delivery facility, attached to the central administration block, shall be provided. The dirty linen store shall be mechanically ventilated.

6.2.7 Central Production Kitchen

A central production kitchen or localised reconstitution kitchen (as deemed appropriate) shall be designed and operated in accordance with the requirements of:

- Food Act Western Australia – 2008,
- Food Regulations – Western Australia – 2009
- Australia New Zealand Food Standards Code; Food safety standards Chapter 3.2.3 Food Premises and Equipment
- Food hygiene regulations and relevant WorkSafe WA requirements.

The design of the central kitchen and associated storage areas should be carefully considered to ensure a high quality food service.

Where the central production kitchen utilises gas appliances, an emergency gas isolation valve shall be installed in a location that is easily accessible during emergency egress.

Where central kitchens provide meals to other facilities, the Australia New Zealand Food Standards Code, code of Practice for Meals on Wheels (however titled) services shall be observed.

6.2.8 Central Dining Room

A central dining room, located as part of the central amenities area, shall be large enough to accommodate the number of residents to use the room in one sitting.

6.2.9 Storage

Adequate, accessible and secure storage areas shall be provided for the storage of stationary, equipment, general and medical supplies, consumables and records. Where possible, storage requirements should be discussed with the management of the Psychiatric Hostel. Storage must be like for like with no mixed use storage.

6.2.10 Bin Areas and Rubbish Collection

Provision shall be made for the storage and collection of rubbish.

Bins should be stored in a bin enclosure or ventilated storeroom. An associated facility for washing bins shall be provided.

Discussions should be held with the local authority regarding bin store requirements, rubbish collection, manoeuvrability of rubbish trucks and bin provision.

6.2.11 Plant and Equipment Spaces

Provision shall be made for the necessary rooms or cupboards for plant and equipment. This includes spaces for the location of concealed fire hose reels, fire hydrants, electrical and telecommunications equipment, mechanical plant and plumbing services.

6.3 Construction

Construction should be appropriate to suit the desired home-like architectural style. The materials and detailing should emphasise the home-like nature of the Psychiatric Hostel.

Construction materials and detailing shall comply with the requirements of the Building Code of Australia (NCC).

The construction materials and detailing shall enhance the home-like qualities of the Psychiatric Hostel and reflect the needs of the intended resident. Resident safety shall be a prime consideration in the construction of the Psychiatric Hostel (refer to section 4.4 – Safety).

The construction materials and detailing should adopt a maintenance minimisation approach within the given cost parameters.

Care should be given to the joining of materials to ensure smooth junctions to prevent injury.

6.4 Security

Resident and staff security shall be considered. The movement of staff between buildings at night requires special attention.

A Psychiatric Hostel is a 24 hour operation with staff entering and leaving at various times. At these times the potential for unauthorised entry into the building exists. Attention should be given to home-like fencing, lighting (internal and external), locking systems, enclosed walkways, drug storage and security systems generally.

6.5 Glazing

All glazing shall be in accordance with the requirements of AS 1288 and AS/NZS 2208. Due to the nature of the resident group (who may have unsteady gait or blurred vision due to psychotropic medication), the use of full height glazed door and window panels, low level glazing and large mirror panels are generally not recommended.

If large glazed panels are utilised then consideration shall be given to increasing the safety margin in relation to the Australian Standard, and the placement of a visual cue on the glass panel.

6.6 Maintenance

The Building Code of Australia covers briefly the need to maintain the building so that it does not deteriorate to the extent of endangering residents. It also gives consideration to maintenance in the areas of:

- safety installations
- mechanical ventilation and warm water systems compliance with AS/NZS 3666.

In designing and detailing a Psychiatric Hostel facility, the recurrent costs involved in maintaining the building stock are an important consideration. Psychiatric Hostel proprietors should consider the establishment of an asset management program to ensure that building stock is maintained to an appropriate standard.

The architect and engineers should minimise the impact of maintenance on the life cycle costs of the facility, with consideration to the proprietor's capital commitment. Selection of building materials, finishes, fitments, plant, etc., and maintenance access, are all-important considerations.

The aim of the above is to prevent the building from deteriorating. The Director General, under the *Private Hospitals and Health Services Act 1927*, may need to consider the withdrawal of the Psychiatric Hostel licence if the building stock is deemed in any way to be unsafe.

7. Interior Design

7.1 General

A home-like interior shall be created in the development of new Psychiatric Hostels and the remodelling of existing Psychiatric Hostels.

Careful consideration shall be given to the selection and co-ordination of furnishings, fittings, finishes and internal detailing to enhance the home-like qualities of the Psychiatric Hostel. Attention should also be given to the importance and impact of the use of colour.

Décor involves style, atmosphere, colour, materials, textures, forms and the effects of light. The appeal or lack of appeal to the individual of a particular décor is based upon that individual's perception of the collective whole and is highly subjective.

Historically, in Psychiatric Hostel design, there have been rigid commitments to particular selections or avoidance in the area of décor, especially with regard to colour. Interior design, when empirically tested, has proven to be beneficial to the overall wellbeing of the resident.

The Hostel designer is advised to show fresh initiative in décor selection, keeping in mind the following points:

- the dimensions of colour: hue, intensity, tone, temperature
- the differing effects of various types of light upon colour and vice versa
- potential to provide variety through change of texture and surface
- visual dynamics and balance
- proportion and its effects
- re-decoration is not a budgetary priority so care in selection of materials and colour is important
- extremes of colour should be avoided.

The ease of cleaning, ongoing costs, efficient maintenance and safety of residents are important considerations.

7.2 Finishes

Design Objective

Finishes should be of an appropriate character. Whilst consideration needs to be given to maintenance, the selected finishes and detailing should not give an institutional feel of indestructibility.

Floor finishes shall be impervious and slip-resistant in wet areas (e.g. mosaic ceramic tiles or slip resistant vinyl in bathrooms/toilets, sheet vinyl in service areas, etc.) and as deemed appropriate in the resident living and relaxation areas (e.g. carpet or a residential patterned vinyl). In wet areas, coved skirting shall be provided. Slip resistance of finishes to comply with AS 4586.

Carpet provides benefits with regard to comfort and home-like appearance. Carpet selection shall comply with the requirements of AS1428.1.

However, consideration must be given to the ease with which it can be cleaned and its ability to contain liquid spills (to prevent contamination of the sub floor).

Carpets, vinyls, curtains and other wall and floor finishes installed in all Psychiatric Hostels shall be inherently fire retardant and have Early Fire Hazard Indices in accordance with the Building Code of Australia (NCC).

Note that floor finishes affect the acoustic performance of the building interior.

7.3 Furniture and equipment

The selection of loose furniture and equipment shall take into account the needs of the residents, and the preferred domestic nature of the building environment.

When purchasing furnishings for use in the Psychiatric Hostel the following points shall be considered:

- Ergonomics and comfort, in particular ease of mounting and dismounting (chairs and beds, etc.).
- Domestic appearance where possible, but not to the exclusion of function. A compromise is often necessary.
- Co-ordination with the remainder of the interior design.
- Worksafe WA requirements.
- Tables with legs that maximise stability.
- Adequate floor area, corridor and door widths for selected beds etc. Large lounge chairs may also require consideration of additional floor area.
- Low fire risk.

Part 4:

Technical Considerations Engineering Services

8. Engineering Services

8.1 General

Unless noted otherwise, psychiatric hostels and group homes shall comply with all sections of the Western Australia Health Facility Guidelines for Engineering Services.

Psychiatric hostels and group homes do not need to comply with the requirements of clauses 6.1.1 to 6.1.4 of the WAHFG's with respect to the requirements for reliability and redundancy criteria.

The following engineering services sections provide clarification, deviations and additional compliance requirements over and above the WAHFG's.

Where there is a contradiction between the Psychiatric Hostel Building Guidelines (PHBG) and the WAHFG's then the PHBG's shall take precedence.

8.2 Mechanical services

8.2.1 Heating/Cooling/Ventilation – General

Heating, cooling and ventilation shall be provided as required under this section to ensure reasonable comfort in all resident service areas and shall comply with WAHFG's for psychiatric hostels.

Controls are to be readily accessible and easily used by residents in areas such as residents' rooms. In psychiatric communal areas it is desirable to have these controls under the control of staff.

Unless otherwise required, areas should ideally be maintained within the range of 20 degrees Celsius to 25 degrees Celsius. The winter set point shall generally be 22 degrees + 1 degree Celsius. The summer set point shall generally be 24 degrees Celsius + 1 degree Celsius. These may be adjusted to suit local preferences. Air conditioning, with appropriate fresh air provision as stated herein, is the most effective means of providing acceptable environmental conditions for residents.

8.2.2 Heating

An adequate and safe heating system shall be provided for all facilities, including bath and shower areas, in locations where the average minimum temperature in any month falls below 10 degrees Celsius.

Heating is recommended where inside temperatures will not remain within accepted comfort levels at all times.

Gas heaters shall be installed where the equipment is visible, readily accessible and easily maintainable. Gas heaters shall have flues to the outside.

Where gas heaters are not installed in such locations they shall be enclosed in a structure that shall not hinder maintenance and inspection but which shall provide a minimum fire resistance level of 60/60/60. In such cases, the enclosure shall be protected by a smoke alarm connected to the Fire Indicator Panel (FIP).

8.2.3 Cooling

Air conditioning is recommended for all occupied areas.

Lounge rooms, day/dining spaces, the study, etc. shall be provided with both heating and cooling. Air conditioning is recommended, although alternatives may be considered.

Where evaporative cooling is used, the systems shall be readily and safely accessible for cleaning and arranged to have dry sumps when switched off to minimise Legionella risk. The sanitation procedure for bacterial control in accordance with AS/NZS 3666 shall be detailed in the Maintenance Manual provided to the client.

Bedrooms shall have as a minimum circulating fans providing adequate air movement.

Fans may be used in conjunction with heating and cooling equipment for economy of operation.

8.2.4 Ventilation requirements

8.2.4.1 Outdoor air

For psychiatric units ventilation shall comply with the WAHFG's. Note that air movement requirements for wards does not apply to residents rooms.

Where not required for positive air flow control, induced make-up air may be considered equivalent to fresh air, provided the source is not contaminated and complies with the BCA requirements for "borrowed" air.

Forced outside air shall be provided in accordance with these guidelines to all occupied spaces regardless of whether the area is served via openable windows.

For group care, outside air via openable windows may suffice if NCC BCA compatible.

8.2.4.2 Exhaust air

For psychiatric units exhaust air provisions shall comply with West Australian Health Facility Guidelines for Engineering Services.

For group rooms exhaust provision shall be in accordance with BCA and AS 1668.2.

Exhaust air discharges shall be in accordance with AS 1668.2.

Clean areas shall not be ventilated by systems serving sanitary compartments, dirty utility rooms and similar spaces.

For psychiatric units contaminated exhaust systems, including those serving toilets, and those necessary to attain positive air flow from clean to dirty areas shall be fitted with differential pressure switches to provide visual indication of fan failure in a continuously occupied area or by remote alarm.

Dispensations to the above provision may be considered, provided dispensation is obtained from the local authority to independent toilet exhaust systems serving single toilet/shower or bath areas.

Acoustic isolation and transfer ducts shall be provided for make-up air supply for shared use ensuite toilets and where toilets have doors, which open directly onto public areas or thoroughfares.

Kitchen areas shall be ventilated in accordance with Food Hygiene Regulations and AS 1668.2.

8.2.4.3 Ventilation rates

The following areas shall have Exhaust ventilation rates shall comply with the WAHFG's.

Ensuites (incorporating showers):

- Single Resident,
- Shared Resident,
- Resident Bathrooms,
- Dirty Utility Rooms,
- Cleaners' Rooms,
- Smoking Room,
- Soiled Linen Holding Rooms, and
- Soiled Linen Cupboards.

Corridors may require exhaust ventilation to remove odours associated with incontinent residents, e.g. through naturally or mechanically ventilated roof lights.

8.2.4.4 Air handling systems

All air handling systems shall comply with the WAHFG's.

8.2.4.5 Legionella prevention

The recommendations and requirements of AS/NZS 3666 shall apply.

8.2.4.6 Air filtration

Air filtration shall comply with the WAHFG's.

8.2.4.7 Linen processing areas – Special requirements

Psychiatric Hostels incorporating a staff operated laundry shall comply with the WAHFG's.

The filtration, mechanical ventilation and air conditioning systems servicing this area shall be designed to ensure appropriate lint dust control viz. high level laminar supply combined with low level exhaust with lint filters.

The mechanical services systems shall also be designed to deal with the heat generated by the laundry drying process, e.g. exhaust registers over the dryers and/or dryers ducted direct to outside air with lint collection provision on all exhaust discharges.

Provision shall be made for regular maintenance to prevent the excessive build-up of lint dust, which can be the source of a fire hazard.

Spot cooling with air-conditioned or evaporative cooled supply air should be considered to provide adequate operator comfort in laundries.

8.3 Electrical service

Particular emphasis shall be placed on the safety and reliability of the installed service.

8.3.1 Switchboards

Switchboards distributing electricity shall:

- be located in readily accessible, well illuminated areas where they cannot obstruct means of emergency egress; and
- be mounted in a secure location, be accessible only to authorised personnel.

8.3.1.1 External lighting

Where entrances and exits are used by staff, residents and the public after dark and do not abut a public thoroughfare, the pathway from each entrance or exit to the public thoroughfare shall be illuminated to meet or exceed the requirements of lighting sub-category P1 of AS 1158.3.1.

All other external paths of travel shall be illuminated to a level not less than that detailed in AS 1158.3.1.

External lighting design shall take into account the need to maintain personal safety and security.

8.3.2 Wall and ceiling fans

The installation of electric wall and ceiling fans shall comply with the requirements of AS 3000 and the Health (Public Buildings) Regulations.

Where wall mounted fans are provided they shall be installed in permanent positions with the blades at least 2100mm above the floor and adequately protected by guards of robust construction.

Ceiling mounted fans shall be installed with the blades at least 2400mm above the floor, unless adequately protected from accidental physical contact.

8.3.10 Alarm systems

Alarm systems for Fire, Alert and Evacuation, and other similar systems require to suit the Psychiatric Hostel functions, shall be connected to uninterruptable power supply.

8.4 Communications

8.4.1 Telephone system

An efficient internal and external telephonic communication system shall be provided to administration and any other area deemed necessary in Psychiatric Hostels only.

Facilities shall be available for the reception of calls 24 hours per day. Night switching to alternative staffed areas after normal administrative hours is considered acceptable.

Primary external communication shall be maintained in the event of a major power failure.

Provision shall be made for residents to make external calls, at any time, in an area convenient to the resident, either through a Psychiatric Hostel handset in the administration area, or a suitable pay telephone.

Such provisions shall be accessible to disabled residents.

8.4.2 Messaging system

A messaging system may be used to supplement the Psychiatric Hostel telephone system for contact with key staff members.

This facility may include arrangements for assistance call and other emergency signals.

Where a paging system is installed, automatic interface with the fire alarm system is recommended.

Messaging systems shall be maintained in the event of a major power failure and connected to uninterruptable power supply.

8.4.4. Patient nurse call

A patient nurse call system should be considered by the Proprietor, however is not deemed to be mandatory.

Where a patient call system is provided, the system shall comply with the WAHFG's.

8.4.5 Staff assistance call

A staff assistance call system should be considered by the Proprietor, however is not deemed to be mandatory.

Where a patient call system is provided, the system shall comply with the WAHFG's.

8.4.5 Resident entertainment

Provision shall be made for suitable and appropriate resident entertainment facilities in resident recreation areas (e.g. television, video, radio, music etc.).

Trolley mounted television sets are not recommended due to the Occupational Health and Safety implications of obstruction, collision and toppling.

8.5 Electronic security systems

8.5.1 Door security – Psychiatric Hostels only

An effective system of door communication and/or monitoring shall be provided to allow after hours visitors to be remotely assessed from an appropriate area, prior to personal contact. This precaution provides staff security reassurance.

Staff only areas shall be secure from resident and public areas and this should be achieved through the use of access controlled doors with door open too long alarms.

8.5.2 Duress alarms – Psychiatric Hostels only

A duress alarm system shall be provided for staff safety. This should consist of both fixed duress alarms as well as mobile duress alarm systems reporting back to the following:

- Permanently staffed workstation or similar appropriate location;
- A messaging system to alert to portable devices; and/or
- A security monitoring firm.

The system solution for the duress alarm system shall be defined by the security risk assessment.

8.6 Lifts

All Psychiatric Hostels with resident facilities (such as bedrooms, dining rooms, recreation rooms etc.) located on other than the ground level entrance floor (single level, direct flat or ramp egress to open external spaces), shall have one (or more) electric or electro hydraulic lifts as specified in the Health Department of WA Private Hospital Guidelines.

Cabin size shall accommodate the length of an occupied emergency trolley as used by St Johns Ambulance.

8.7 Hydraulics

8.7.1 Hot Water Supply

Hot Water Supply shall comply with the WAHFG's expect for:

- Group Homes to not have to comply with either section 13.4.1 or 13.4.2 of the WAHFG. No redundancy is required within the hot water system.

8.7.2 Cold Water Supply

Cold Water Supply shall comply with the WAHFG's expect for:

- Group Homes do not have to comply with sections 13.3.3, 13.3.4, 13.7.2 of the WAHFG.

8.7.2.1 Water treatment

Water quality shall comply with the WAHFG and where required treatment systems shall be installed.

8.7.2.2 Legionella prevention

In regards to Legionella prevention the design shall follow and comply with the WAHFG.

8.7.2.3 Backflow prevention

Backflow prevention shall comply with the WAHFG.

8.8.1 Fire service

The fire service shall be as detailed in the BCA and to the requirements of the fire brigade (DFES).

8.8.2 Sewerage and sanitary plumbing

The design shall comply with WAHFG.

8.8.3 Storm water

The design shall comply with WAHFG.

8.8.4 Natural gas service

The design shall comply with WAHFG with exception that the gas pressure for Group homes shall be limited to 1.25 kPa.

8.8.5 Industrial waste and drainage Service 7

The design shall comply with WAHFG. Grease arrestor traps shall be installed for kitchen areas in Psychiatric Hostels only.

8.8.6 Hydraulic equipment

The design shall comply with WAHFG.

9. Fire Safety Guidelines

9.1 Design requirements

Psychiatric Hostel buildings, services and equipment shall be designed and constructed in accordance with the requirements outlined in the Building Code of Australia (BCA). The reference classification is Class 3 for Hostels, although other sections may also be appropriate.

9.2 Staff awareness

Fire evacuation drills shall be carried out every six months.

A fire safety training program shall be conducted for all staff at least annually and must include an introduction and training package for new staff.

9.2 Maintenance

Maintenance of all fire safety systems, including passive and active systems, shall be conducted in accordance with AS 1851-2012.

All relevant baseline data shall be kept onsite at all times, and updated as required.

Unit management shall ensure all fire fighting equipment, together with fire detection and alarm systems, are maintained in good order, and where appropriate, in accordance with the relevant Australian Standard.

Part 5:

Group Home Design Considerations

10. Planning and Design of Group Homes

10.1 General

The guidelines represent minimum standards for the establishment of Group Homes.

Group Homes shall be designed and constructed in accordance with the requirements of the National Construction Code. The reference classification is 1B.

The focus of Group Home design is to encourage individuals to establish or maintain independence within the community. While staff members are available to offer psychosocial support, residents are responsible for the running of the household including cooking, cleaning and budgeting. The group home is often a 'stepping stone' for the residents, enabling them to develop the necessary living and interpersonal skills that will equip them for living independently in the wider community.

10.2 Design of a Group Home

The Design of the Group Home is essentially a typical residential dwelling, with consideration given to the specific needs of the client group being serviced.

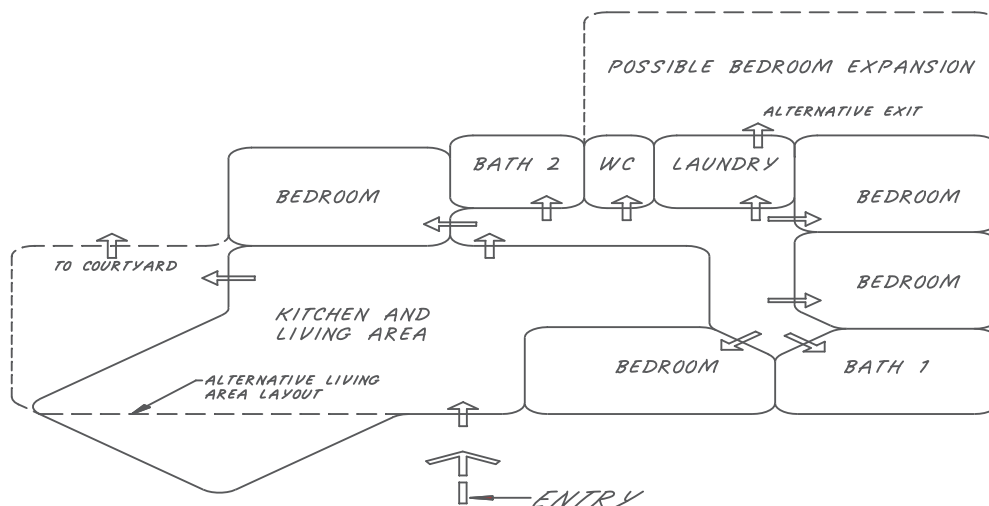

Bubble diagram of group home – typical layout

The architectural style should be sympathetic to the streetscape or adjacent buildings and should not 'single out' the premises as other than a residential facility.

10.3 Achieving appropriate outcomes

It is recommended that in order to achieve the desired design outcome the following are taken into consideration:

- Experienced professional consultants (architects, engineers, interior designers, etc.) should be commissioned.
- Staff and residents should be consulted about their needs and priorities.
- On-going negotiation and discussion with the relevant State representatives shall occur.

10.4 Design principles

These principles should be considered for Group Home design. The following issues should be carefully resolved:

- **Security** – including entry/exit control to the facility and to resident bedrooms. Medication storage in resident bedrooms must be secure.
- **Location** – Site location should be considered. In particular, proximity to services such as banks, shops, public transport and other core services is an important aspect of promoting independence.

10.5 Smoke Free Environment

The right to a smoke free environment within the Group Home is to be guaranteed. However, consideration should be given to the needs of residents and visitors who smoke, i.e. provision of an appropriate smoking area. The design of the smoking area shall be consistent with current legislation related to smoking in the workplace and enclosed public areas.

10.6 Occupational Health

The occupational health, safety and welfare of staff shall be considered in the design of a Group Home. Current WorkSafe practices and legislation shall be adopted.

10.7 Safety

All detailing within the Group Home shall consider the particular needs of a client group who, from time to time, may display high levels of expressed emotion. This may be manifested in the form of random acts of aggression, either self directed (in the form of self-harming behaviour) or directed at the facility.

The design of the Group Home should reflect this possibility in its design and fit out.

A first aid kit should be available in the group home for use by residents and staff.

11. Site

11.1 Location

The site selected for the Group Home should facilitate community access and encourage residents' independence and promote quality of life.

The proposed development should be compatible with the current and future land use and zoning. The site should enable the Group Home to blend with the local environment and to become a desirable place to live.

The location should enhance community service delivery. A range of services should be accessible within the local community to enable the resident to maintain community ties and foster independence. Services should include public transport, pharmacy, banking, dentist, hospital, department store, and library.

11.2 Site planning

Site planning requires consideration of the needs of the users, the impact on neighbours and the presence of the facility within the community. Site planning also includes consideration of roadways, car parking, walkways, outdoor access, gardens, servicing and signage.

11.2.1 Needs of users

When the general suitability of the site for a Group Home has been assessed, consideration should be given to detailed site planning with a focus on the needs of users (i.e. residents, staff, visitors and suppliers).

In considering the site, features such as topography, views, vegetation, drainage, access, orientation and micro-climate should be assessed and positive features incorporated into the design. Well-considered site planning can contribute to personal safety, property security, energy efficiency and water conservation.

Careful site planning can significantly enhance the living environment for the future users of the Group Home.

11.2.2 Impact on neighbours

The interface between the Group Home and neighbouring areas should also be carefully considered. Privacy of neighbours and residents should be developed through careful placement of windows, fences and planting.

- Pedestrian and vehicle access to the site shall be incorporated.
- Visual links to views or features of significance shall be considered.
- Car parking should be discretely located and should not dominate views. Sufficient car parking needs to be provided to satisfy the needs of residents, staff and visitors. The provision of car parking should not visually impact on neighbours.

Provision of disabled parking shall be provided as required by the Building Code of Australia, (NCC).

- Neighbouring areas may expose the site to detrimental impacts (e.g. excessive traffic noise). These impacts shall be minimised to improve the environment for all users.

11.2.3 Community

Consideration should be given to the image the Group Home projects within the community. The image should demonstrate that residents are valued people. The Group Home should blend into the neighbouring environment and it should fit within the surrounding neighbourhood's character.

11.2.4 Outdoor access and gardens

The Group Home shall provide access to useable external spaces, incorporating disabled access. The external spaces should include pathways, seating and pergolas. Landscaping, both hard and soft, should provide as home-like an environment as possible.

Particular attention needs to be paid to the provision of adequate structured shade.

Outdoor areas should also have garden/security lighting to illuminate pathways and entrance areas.

11.2.5 Disabled access

Disabled access shall be provided to the premises in accordance with the relevant AS1428.1

Buildings and parts of buildings that require to be accessible shall comply with the NCC – Part D3.1 General building access requirements. (Table 3.1) Group Home building class 1b.

12. Group Home Construction

12.1 General

Construction materials and detailing shall comply with the requirements of the Building Code of Australia (NCC).

The construction materials and detailing shall reflect the needs of the intended resident. Resident safety shall be a prime consideration in the construction of the Group Home (refer to section 4.4 – Safety).

The construction materials and detailing should adopt a maintenance minimisation approach within the given cost parameters.

12.2 Bedrooms

Bedrooms in Group Homes may accommodate one or two residents, but single bedrooms are preferred. Bedrooms designed for more than two beds shall not be permitted.

The bedrooms shall be sized to provide for both bed and sitting space, thereby allowing for personal and social activities

In the Group Home, the minimum size of a single bed resident room should be 12 sqM. Size may need to be varied dependent upon position of door(s) and window features, furniture layout, extent of additional furniture (book cases, desks, TV), etc. A bedroom shall not be used as a thoroughfare to rooms other than ensuite toilets, closets, or dressing rooms that are for the exclusive use of the occupant(s) of that bedroom. Bedrooms should not open directly into communal living areas, kitchen or other service areas. Bay windows are considered to be an advantage in that they provide additional useable floor space for sitting activities.

12.3 Showers, toilets, basins and baths – Generally

This section only describes minimum provision for showers, toilets, basins and baths.

Showers, toilets, basins and baths shall be residential in fitout and detailing, and consideration shall be given to resident safety as referred to in section 10.7.

Acoustic privacy is also very important in shared facilities. Solid or medium core doors shall be installed with air transfer ducts, not door grilles, for supply air.

In the group home with one shower/toilet provided, the design focus should be consistent with AS 1428.1. Where the group home has more than one shower/toilet facility provided, only one shower/toilet needs to meet AS 1428.1.

The onerous implications of compliance with this standard is understood and in existing facilities a dispensation for non-compliance may be considered by LARU following a written request by the proprietor, with a detailed rationale addressing the requirement to provide equitable access to services and premises legislated under the DDA.

All new or remodelled facilities shall comply with the NCC and the requirement for provision of accessible facilities and a dispensation will not be considered.

A bath should be considered within the facility for those who prefer bathing to showering.

12.3.1 Toilets

Sufficient toilets shall be provided in accordance with NCC. Toilet seat lids shall be provided to all toilets, except to the accessible toilet. All toilet seats should be securely fixed with lateral stability and fixings to comply with AS 1371.

The accessible toilet as required by NCC for residents with disabilities should have a design focus consistent and shall comply with the requirements of AS 1428.1, although the toilet installation required special consideration.

In particular the dimension, from the rear wall to the front of the pan, in AS 1428.1 (800 mm) is excessive. The distance from the front of the cistern to the front of the pan shall be approximately 600mm (720mm from rear wall to front of pan).

12.3.2 Basins

Basin shall be provided in every room where there is a toilet and the size of the handbasin shall enable effective handwashing to occur.

In the required accessible bathrooms, the basin configuration shall be according to AS 1428.1 is considered appropriate.

Tapware should be chosen that is simple for residents to use (refer Section 12.4 – Plumbing Fittings).

Consideration shall be given to the size of the hand basin, ensuring the size will enable hand washing to occur. Basins with overflow outlets shall not be provided in areas where infection control is critical, that is kitchen and consulting rooms.

Mirrors over the basins are also required. The bottom of the mirror should be no higher than 900mm to a height of not less than 1850mm above the plane of the floor. Mirrors shall be securely fitted and shall be of safety glass or other appropriate material resistant to excessive impact.

A basin with a vanity unit should be considered to be incorporated in ensuites.

Hand washing facilities shall be securely anchored to withstand an applied vertical load of not less than 115kg on the front of the fixture.

12.3.3 Grip bars

Where fitted, grip bars shall be detailed as described in AS 1428.1, except where otherwise noted in this document. Grip bars, vertical adjustable shower supports, towel rails, soap holders, foot rests and any other fixture which may be used for support, shall have sufficient anchorage and strength to resist the sustained concentrated load of a falling heavy human.

12.3 Plumbing fittings

Location and arrangement of fittings for whatever purpose shall permit their proper use and operation.

Non-thermal transmitting handles are preferred with effective finger grips. Hot and cold indicators shall be very clear and the turning action should not require excessive force.

All plumbing installation shall comply with all relevant codes and standards.

12.4 Lounge

Lounge Rooms should be sized to provide comfortable seating and circulation space for the total number of residents and visitors expected to use it at any one time.

Selection of furniture will have an obvious impact on floor area. Indicative furniture layouts should be developed during the planning of the building (refer to Section 13 – Interior Design).

12.5 Family/Meals

A home-like family/meals room shall be provided for each residential facility. It shall be sized to provide space for normal residential type day activities (e.g. Meals, morning/afternoon tea, craft, games, etc.).

Selection of furniture will have an impact on floor area. Indicative furniture layouts should be developed during the planning of the building (refer to Section 13 – Interior Design).

12.6 Kitchen

The kitchen shall be capable of preparing meals for the maximum number of occupants of the Group Home. The kitchen should include pantry provision, serving and clean up facilities.

It should also be designed for partial access by the disabled, e.g. pull out shelf or partially open under bench, lower height bench, etc.

The hot plate and oven should be electric, should have on/off lights for each hotplate and have front located controls.

Design of the kitchen shall consider resident safety as referred to in section 10.7.

12.7 Laundry

The laundry should provide space for a washing machine and clothes dryer and contain a trough, bench and space for an ironing board. External drying areas shall also be provided.

Consideration shall be given to the size and durability of appliances used.

12.8 Medication storage

The storage of medication shall be considered. Adequate lockable storage shall be provided in each individual's room or within the group home. Staff shall hold a master key for all storage areas.

12.9 Windows, screens and grilles

All rooms shall have glazed windows or doors to achieve external views and/or make use of direct or borrowed natural light.

Resident bedrooms shall have windows overlooking external areas.

An external area is a perimeter space around a building, a naturally ventilated and lit atrium or a courtyard.

Each external window and/or external glazed door panel area shall be not less than 10% of the floor area of the room concerned. An opening component equal to not less than 5% of the floor area of the same room should be provided. These requirements together will ensure natural light and ventilation in the event of an electrical failure.

External windows shall be fitted with flyscreens and consideration should be given to the installation of security screens/grilles. In addition windows shall have blinds and/or curtains. External shading devices should also be considered. These measures should provide effective control of direct sunlight and glare from external sources.

Windows are not to be obstructed by furniture, partitions, etc.

12.10 Doors

The minimum dimension for clear door openings to resident bedrooms/corridors etc. shall be in accordance with BCA requirements.

Rooms that contain baths, showers or toilets shall be equipped with door hardware that will permit emergency access from the outside. As these rooms are generally only small in size, and particularly where door openings are narrow, the doors should be capable of opening outwards or in a manner that negates the need to push against the resident who may have collapsed or secured themselves within the room.

All Group Homes shall have a rational master key system. Locks shall be provided to bedrooms, stores, offices etc., as appropriate.

Security flyscreen doors where installed, shall not compromise emergency egress.

12.11 Glazing

All glazing shall be in accordance with the requirements of AS 1288 and AS/NZS 2208. Due to the nature of the resident group (who may have unsteady gait or blurred vision due to psychotropic medication), the use of full height glazed door and window panels, low level glazing and large mirror panels is generally not recommended. If large glazed panels are utilised then consideration shall be given to increasing the safety margin in relation to the Australian Standard, and the placement of a visual cue on the glass panel.

12.12 Maintenance

The Building Code of Australia Section E5 covers briefly the need to maintain the building so that it does not deteriorate to the extent of endangering residents. Section E5 also gives consideration to maintenance in the areas of:

- safety installations
- mechanical ventilation and warm water systems compliance with AS/NZS 3666.

In designing and detailing a Group Home, the recurrent costs involved in maintaining the building stock are an important consideration. Proprietors should consider the establishment of an asset management program to ensure that building stock is maintained to an appropriate standard.

The architect and engineers should minimise the impact of maintenance on the life cycle costs of the facility, with consideration to the proprietor's capital commitment. Selection of building materials, finishes, fitments, and maintenance access, are all-important considerations.

The aim of the above is to prevent the building from deteriorating.

The Director General, under the *Private Hospitals and Health Services Act 1927*, may need to consider the withdrawal of the Group Home licence if the building stock is deemed in any way to be unsafe.

13. Interior Design

13.1 General

Careful consideration shall be given to the selection and co-ordination of furnishings, fittings, finishes and internal detailing of the Group Home.

Décor involves style, atmosphere, colour, materials, textures, forms and the effects of light. The appeal or lack of appeal to the individual of a particular décor is based upon that individual's perception of the collective whole and is highly subjective.

The designer is advised to show fresh initiative in décor selection, keeping in mind the following points:

- the dimensions of colour: hue, intensity, tone, temperature
- the differing effects of various types of light upon colour and vice versa
- potential to provide variety through change of texture and surface
- visual dynamics and balance
- proportion and its effects
- re-decoration is not a budgetary priority so care in selection of materials and colour is important
- extremes of colour should be avoided
- low fire risk.

The ease of cleaning, costs and efficient maintenance and safety are important considerations.

13.2 Finishes

Floor finishes shall be consistent with usage. Living and bedroom areas should have floor finishes as would a residential home, (e.g. carpet or a residential patterned vinyl). In kitchen and wet areas, floor finishes shall be impervious and slip-resistant (e.g. mosaic ceramic tiles or slip resistant vinyl in bathrooms/toilets, sheet vinyl in kitchens). In wet areas, coved skirting shall be provided.

Carpets, vinyls, curtains and other wall and floor finishes installed in all Group Homes shall be inherently fire retardant and have Early Fire Hazard Indices in accordance with section C1.10 of the Building Code of Australia (NCC).

Note that floor finishes affect the acoustic performance of the building interior.

13.3 Furnishings

Furnishings and fittings shall be domestic in nature and should be consistent with the following design principles.

- Furnishings shall be co-ordinated with the interior design of the group home
- Have a low fire risk.

14. Engineering Services

14.1 Mechanical Services

The certification of the Mechanical Services installation shall be undertaken by a professional consulting Engineer experienced in residential home services design, with Corporate Membership of the Institution of Engineers, Australia and relevant NPER-3 Registration.

The professional Engineer shall certify all test data and that the design complies with all statutory requirements and these guidelines.

The mechanical contractor or consulting engineer shall certify that the installation complies with the documentation and the mandatory requirements established or implied with the “Approval to Construct”.

Special consideration should be given to the following items in mechanical service design:

- reliability of operation
- ease of maintenance and selection of systems with a minimum of components requiring maintenance
- effective system management
- select equipment with minimum noise and vibration characteristics
- select equipment with stable operating points and below their maximum limits for capacity speed, temperature and pressure within bounds of energy management
- energy conservation
- the safety of residents (refer to section 10.7 – Safety).

14.2 Heating, cooling and ventilation – Generally

Heating, cooling and ventilation shall be provided as required under this section to ensure reasonable comfort for residents within the Group Home.

Controls are to be readily accessible and easily used by residents.

Air conditioning, with appropriate fresh air provision as stated herein, is the most effective means of providing acceptable environmental conditions for residents.

14.2.1 Heating

An adequate and safe heating system shall be provided for all facilities, including bath and shower areas, in locations where the average minimum temperature in any month falls below 10 degrees Celsius. Heating is recommended where inside temperatures will not remain within accepted comfort levels at all times.

Bedrooms shall have, as a minimum a wall mounted strip heater (refer to section 8.2.6 – Electric Room Heaters for details).

Gas heaters shall be installed where the equipment is visible, readily accessible and easily maintainable. Gas heaters shall have flues to the outside.

Where gas heaters are not installed in such locations they shall be enclosed in a structure that shall not hinder maintenance and inspection but which shall provide a minimum fire resistance level of 60/60/60. In such cases, the enclosure shall be protected by a smoke alarm connected to the Fire Indicator Board (FIB).

14.2.2 Cooling

Where evaporative cooling is used, the systems shall be readily and safely accessible for cleaning and arranged to have dry sumps when switched off to minimise Legionella risk. The sanitation procedure for bacterial control in accordance with AS/NZS 3666 shall be detailed in the Maintenance Manual provided to the client.

Bedrooms shall have as a minimum circulating fans providing adequate air movement.

Ceiling sweep fans, where provided, shall be as described in the Psychiatric Hostel Guidelines, Section 8.2.7. Fans may be used in conjunction with heating and cooling equipment for economy of operation in mid season.

14.2.3 Ventilation requirements

14.2.3.1 Outdoor air

Outdoor air intakes shall be located in accordance with AS 1668.2 Clause 2.2 to ensure the supply is of adequate quality.

Except as otherwise required in these guidelines, outdoor air provisions shall be in accordance with the Building Code of Australia (BCA) and AS 1668.2.

Where class of occupancy is not specifically listed in Table A.1 under “Health Care”, an equivalent class of occupancy from other areas of the Table shall be used.

Where not required for positive air flow control, induced make-up air may be considered equivalent to fresh air, provided the source is not contaminated and complies with the BCA requirements for “borrowed” air.

Forced fresh air shall be provided in accordance with these guidelines to all occupied spaces regardless of whether the area is served via openable windows.

14.2.3.2 Exhaust air

Exhaust air provisions shall be in accordance with the BCA and AS1668.2, Table B1.

Exhaust air discharges shall be in accordance with AS 1668.2 Clause 3.7.

Acoustic isolation and transfer ducts shall be provided for make-up air supply for shared use ensuite toilets and where toilets have doors which open directly onto public areas or thoroughfares.

Kitchen areas shall be ventilated in accordance with Health (Food Hygiene) Regulations of the Health Act and AS 1668.2.

14.2.3.3 Ventilation rates

The following areas shall have exhaust ventilation rates that are the greater of either those shown below or the requirements of AS 1668.2 Table B.1.

Ensuites (Incorporating showers):

- Single Resident: 10 L/s. m²
- Shared Resident: 15 L/s. m²
- Resident Bathrooms: 15 L/s. m²
- Smoking Room: 15 L/s. m²

14.2.3.4 Air Handling systems

All air handling systems shall be designed and operated in accordance with AS 1668.1. Where systems fall outside the jurisdiction of this standard, all supply air systems, except for unitary equipment, shall automatically shut down on any fire alarm signal in the area served by that system.

Ductwork shall comply with the requirements of the BCA, AS 1668.1 and AS 4254.

Flexible ductwork shall comply with the requirements of the Building Code of Australia and have test certification to AS 1530.2 and AS 1530.3 for the following minimum indices:

- Spread of Flame 0
- Smoke Developed 3
- Flammability 5

14.2.3.5 Legionella prevention

Air conditioning systems shall be designed, operated and maintained to prevent Legionella and microbes from developing in the systems.

The recommendation and requirements of AS/NZS 3666 shall be complied with.

14.3 Electrical service

Electrical installations shall comply with the requirements of AS 3000, the Supply Authority, the Building Code of Australia, these guidelines and other relevant Australian Standards.

The design, witnessing of all relevant tests and certification of the Group Home electrical installation shall be undertaken by an appropriately qualified and experienced professional Engineer with Corporate Membership of the Institution of Engineers, Australia and/or relevant NPER-3 Registration. The professional Engineer shall certify all tests and that the design complies with all statutory requirements and with these guidelines.

The electrical contractor or consulting engineer shall certify that the installation complies with the documentation and the mandatory requirements established or implied with the "Approval to Construct".

Particular emphasis shall be placed on the safety and reliability of the installed service.

14.3.1 Switchboards

Switchboards, where required, shall comply with the requirements outlined in section 8.2.1.

14.3.2 Cabling (General)

All electrical cabling installed in a private Group Home shall comply with the requirements of AS 3008.1, AS 3009.

Consideration should be given to running of cabling with a 25 per cent spare capacity over the calculated maximum demand.

14.3.3 Lighting

All areas of the Group Home shall be adequately illuminated by natural or artificial means, to afford safe movement commensurate with the purposes of each area. Artificial lighting shall be by means of electricity.

The level of general lighting provided throughout shall be not less than the recommended service illuminance levels listed in AS 1680.

Light and power switches shall be of robust construction with heavy-duty mechanisms.

Mixed power and lighting circuits are not permitted other than single phase extraction fans in single toilet, shower, bathroom or other approved areas, which may be connected and switched with the light fitting.

Where working positions are fixed, advantage may be taken of the AS 1680.2.0 task lighting provisions.

14.3.4 General-purpose power outlets

An adequate number of general-purpose power outlets shall be provided for all anticipated uses.

One outlet shall be provided for every appliance in use at any one time, or if appliances are left plugged in, one outlet for each appliance.

Piggyback plugs, double adapters and power boards shall not be utilised.

Circuit number and phase shall be suitably identified on every power outlet.

Residual Current Devices (RCDs) shall be mounted on distribution boards or integral within outlets. Power outlets supplying equipment that is connected by a flexible cord and is not physically fixed in place shall be RCD protected as required by WA Workplace Safety and Health Regulations.

RCD protection shall be provided to the following areas:

- Ensuites, toilets and bathrooms
- Kitchens
- Laundries.

14.3.5 Electric room heaters

The installation of electric room heaters shall comply with the requirements of AS 3000 and the Health (Public Buildings) Regulations.

Where radiant type heaters are provided, they shall be located in fixed positions and installed so that any part of a heating element is at least 2150mm above the floor and positioned in accordance with AS 3000, Section 1.15. Consideration should be given to fitting strip heaters with time delay switches to ensure that they are not accidentally left on, resulting in wasted energy and unnecessary operating cost.

Oil filled, fan type and similar low surface temperature heaters may be installed either as portable or fixed appliances, provided they are fitted with over temperature protection. Fan type heaters shall not be used where excessive airborne lint, powder, or dust is expected.

Consideration should be given to the installation of neon indicators to switch positions for all electric room heaters.

14.3.6 Wall and ceiling fans

The installation of electric wall and ceiling fans shall comply with the requirements of AS 3000 and the Health (Public Buildings) Regulations.

Where wall mounted fans are provided they shall be installed in permanent positions with the blades at least 2100mm above the floor and adequately protected by guards of robust construction.

Ceiling mounted fans shall be installed with the blades at least 2400mm above the floor, unless adequately protected from accidental physical contact.

The potential for strobing where fans are installed in rooms with fluorescent lighting shall also be a design consideration.

Consideration should be given to the matching of electronic fan controllers to the fans to reduce electrical 'hum'.

Consideration should be given to the limitations of the number of fans controlled by one controller to ensure matching of individual fan speeds.

14.3.7 Alarm systems

Alarm systems for Fire, Alert and Evacuation, and others required to suit the Group Home functions, shall be connected to an appropriate battery backup system.

Details of system requirements are covered under their respective sections.

14.3.8 Maintenance of installation

All equipment required by these guidelines shall be regularly inspected and maintained to ensure that the installations are operable at all times.

Wherever Australian Standards cover the maintenance of relevant systems, maintenance shall be in accordance with those standards.

14.4 Communications

14.4.1 Telephone system

An efficient telephonic communication system shall be provided within the Group Home.

Provision shall be made for residents to make or receive calls, at any time, in an area convenient to the resident, within the Group Home. This can be achieved by installation of a domestic phone or by installation of a pay phone.

Such provisions shall be accessible to disabled residents.

14.4.2 Resident entertainment

Provision should be made for suitable and appropriate entertainment facilities in resident living areas (e.g. television, video, radio, etc.).

Trolley mounted television sets are not recommended due to the Occupational Health and Safety implications of obstruction, collision and toppling.

14.5 Hydraulics

The certification of the Hydraulic Services installation shall be undertaken by a professional engineering consultant with experience in Residential Home or Nursing Home hydraulics design. The designer shall certify all test data and that the design complies with all statutory requirements and these guidelines.

The hydraulic consultant or licensed contractor shall certify that the installation complies with the documentation and the mandatory requirements established or implied with the “Approval to Construct”.

The following general provisions shall be satisfied:

- All hydraulic services shall comply with AS 3500 as a minimum standard requirement.
- All materials shall be suitable for their intended service.
- All brass shall be de-zincification resistant (DR) grade.
- Where dew point can be reached, insulation shall be provided to pipework to prevent condensation.
- Pipe materials shall be compatible with the nature and temperature of discharge.

14.5.1 Hot water

An adequate supply of clean hot water shall be reticulated to all resident ablution facilities.

Provision shall be made to limit the supply temperature of hot water to all resident use fittings to eliminate the risk of scalding. Maximum temperature at outlets shall not exceed 46°C for adult residents except that where warm water circuits are used, control of circuit temperature to 50°C maximum is acceptable.

Systems shall be fail safe such that the maximum temperature at the outlet is not exceeded at any time, including when the cold water or power supply fails.

Where hot water is reticulated at low temperature (below 55 degrees Celsius), provision shall be made for suitable sanitising of the system and circuit pipework to prevent the growth of Legionella Bacteria. Aerators, shower roses and other such fittings shall be cleaned and sanitised at regular intervals.

Operation of the system at a temperature above 70° Celsius for one hour each month is one method of protecting warm water systems from the contamination risk, provided the associated operational and healthcare management requirements are complied with. Dual temperature thermostats are suggested for this purpose. Suitable warning signs shall be displayed at all impacted outlets during this process.

Alternatively, an approved chemical disinfection system can be utilised. Proprietary systems such as Rheem Warm Water and Treatment System and Edwards Hot Water could be considered.

Refer to Section 14.5.2.2 – Backflow Prevention and AS/NZS 3666 for further information.

14.5.2 Cold water supply

The Group Home shall be provided with an adequate and safe cold water supply suitable for consumption and ablution purposes.

The water supply system shall be installed in accordance with the requirements of the Water Corporation.

Provision shall be made for the isolation of fixtures, tapware and equipment in logical groupings for service purposes. Records shall be kept of locations of all isolation valves (refer to Section 14.7 – Building and Engineering Manuals). All isolating valves shall be tagged. Resilient seated ball valves are recommended.

The cold water supply system design shall reflect a capacity statement from the supply authority giving minimum (200kPa) and maximum (650kPa) available pressures at probable simultaneous flow of bathroom and other fixtures, plus full flow of continual operating equipment. Excessive dead legs (non recirculatory) normally longer than 6 metres shall have flushing points.

14.5.3 Legionella prevention

Hydraulic systems shall be designed, operated and maintained to prevent Legionella and microbes from developing in the systems.

The recommendation and requirements of AS/NZS 3666 shall be complied with.

14.5.4 Backflow prevention

Backflow prevention of Hot & Cold Water Supplies shall be provided to both existing systems and new installations wherever there is a risk of backflow contamination occurring within the facility's potable water supply.

Backflow prevention shall be provided in accordance with AS 3500, AS 2845 and the Regulations and Bylaws of the Water Corporation.

Backflow prevention should be provided where possible by the use of air gaps. Preference should be given to the use of outlets to provide an air gap and thus eliminate the requirement for other forms of backflow prevention.

However, where air gaps cannot be provided, back flow prevention devices shall be fitted to provide protection to the building occupants and to the Minister's Supply System. Protection shall be agreed with the Water Corporation and be in accordance with the Regulations and By-laws of the Water Corporation and AS 3500.

Prevention of back-flow shall be achieved in shower and bath areas, where an adjustable hand shower is utilised and is in a position where the shower head might sit on the floor of the shower or bath.

The responsible engineer (or the Licence Holder) for the Group Home shall maintain the test certification certificates for later reference.

14.5.5 Identification and signage: Non-potable water

All pipework and outlets with non-potable water shall be identified to comply with the relevant Australian Standards.

The non-potable water pipework (hot and cold) shall be clearly identifiable in both exposed and concealed positions. Identification shall comply with Australian Standard AS 1345 in both colour and letter form.

Signage on non-potable water supply outlets shall be provided in a visible position over or adjacent to non-potable water supply outlets.

14.5.6 Fire service

The fire service shall be as detailed in the BCA and to the requirements of the Fire and Rescue service (F&RS).

Fire hydrants and/or hose reel cabinets shall be bunded and it is recommended that enclosed cabinets incorporate a minimum 50mm diameter floor drain.

14.5.7 Sewerage and sanitary plumbing

All Group Homes shall be provided with an adequate sewerage and sanitary plumbing system. The system shall be either connected to the town sewerage and drainage scheme, or, where specific approval is given, a system conforming to the regulations for Bacteriolytic Treatment of Sewerage and the disposal of effluent and liquid waste under the Health Act.

All sewerage and sanitary plumbing systems shall be designed to comply with the requirements of AS 3500, the Water Corporation bylaws & Regulations and these Guidelines.

Inspection and cleaning facilities shall be positioned external to the building fabric wherever possible. Where this is not possible, inspection and cleaning facilities shall be positioned in ducts or within the wet areas served, wherever possible. Inspection covers located flush with floor finishes shall be chip resistant.

14.5.8 Drains and gullies

Adequate overflow relief gullies shall be provided to minimise back flow into buildings. Floor waste gullies, shower wastes and the like should connect to overflow relief gullies or disconnecter gullies, wherever possible.

Drains shall be provided with adequate manholes and clean out points at ground level for efficient and quick maintenance. Floor waste gully grates and surrounds, industrial floor waste grates and surrounds, and cleanouts and surrounds should be non-slip and of either brass with heavy-duty chrome plating or stainless steel construction.

Baths shall have adequate floor drains adjacent to the edge of the bath.

14.5.9 Storm water

The storm water drainage systems shall be designed generally in accordance with AS 3500, and chapter 2 of the Institute of Engineers Australia publication “Australian Rainfall and Runoff” 1987 edition.

Storm water from buildings and paved areas shall be disposed of in a manner acceptable to the Local Government Authority.

Roof drainage systems shall incorporate separate overflow relief discharge to minimise roof gutter overflow and consequent building damage and service interruptions. Consideration shall also be given to ways of preventing leaf build up in gutters, which in turn has the potential for building damage and service interruption, again due to gutter overflow.

Consideration shall be given to the use of hail guards and the method of connection of Rain Water Pipe (RWP) connections to gutters to allow for expansion/contraction.

RWP’s shall incorporate relief grates at connection between RWP and storm water drain. All RWPs are to have cleaning access at the base.

Consideration shall be given to storm water and soakwell drainage systems also incorporating relief grates, for air and storm water relief.

Storm water drainage grates shall be cross-webbed in car parks and paths and not be located in wheel chair access areas or trolley areas.

Paving areas shall be designed to the intensities nominated in AS 3500.

Channel grates for road or footpath cross over drains shall be of lateral or longitudinal bar design.

14.5.10 Natural gas service

The gas service shall be designed in accordance with the Gas Installation code A6601/19992 and the relevant statutory authority requirements.

14.6 Building and engineering manuals

The building and its engineering services shall be appropriately managed to:

- manage facility related risks, and
- ensure the facility remains appropriate for its intended purpose.

Drawings and manuals shall be created and maintained, and contain all design and construction information required for the effective operation, maintenance and upgrade of the facility through its lifetime.

14.6.1 As-constructed drawings

The Group Home shall maintain an up-to-date set of “as constructed” drawings of the facility. They shall be held in an accessible location at the Group Home for reference by maintenance personnel, fire authorities and other parties having need to reference this information.

The drawings shall show all construction, fixed equipment and mechanical, electrical, structural and hydraulic systems, as installed or built. The position of all buried and concealed services shall be included, with particular reference to isolating valves and cleaning and service points.

Electrical “as constructed” drawings shall be line diagrams which accurately illustrate all circuits, switchboards, and control schematics of all systems and major equipment.

In addition, a schedule of all circuits shall be permanently displayed inside all switchboards.

The drawings shall be accurately maintained throughout the life of the Group Home. All changes shall be incorporated.

The drawings shall be made available to the Director General, as required, to enable an accurate assessment of any proposed work, in particular, remodelling or additions, as part of the licensing procedure.

14.6.2 Equipment manuals

The Group Home shall maintain an up-to-date and complete set of installation, operation and maintenance manuals for installed services and equipment.

Manuals shall contain all quantities, pressures, set points etc., as determined at the time of commissioning, unless adequately shown on the “as constructed” drawings. All commissioning test data shall be retained for reference.

Full operational and maintenance data shall be included on all services and equipment including manufacturer information, parts lists, service agent information, etc.

Manuals shall be accurately maintained through the life of the Group Home. All changes shall be incorporated.

As for 14.6.1 (as Constructed Drawings), the manuals shall be made available to the Director General, as required, to enable an accurate assessment of any proposed work, in particular, remodelling or additions, as part of the licensing procedure.

14.6.3 Certification

The ‘Approval to Occupy Checklist’ details the requirements for certification by engineers and contractors prior to Licensing Standards and Review Unit granting “Approval to Occupy”. Documents and data shall be presented and/or be available in the format as indicated in this checklist.

15. Fire Safety Guidelines For Group Homes

15.1 Design Requirements

Group Homes shall be designed and constructed in accordance with the requirements of the Building code of Australia (BCA). The reference classification is Class 1B. The design shall include, but not necessarily be limited to, the following requirements:

Fire extinguishers with a minimum classification and rating of 1A: 5B: (E) or 5B: 1F: (E) are to be installed in each Group Home.

The walking distance to each extinguisher in the home is not to exceed 15 metres.

Each Group Home is to be provided with a fire blanket to deal with cooking type fires.

Extinguishers and fire blankets are to be located in conspicuous and accessible positions appropriate to the fire risk.

Part 6:

Design Quality

16. Facility Design Checklist

16.1 Facility checklist

The following is provided as the basis for the development of a schedule for a new or remodelled facility.

Residential Facility:

- Bedrooms
- Assisted Shower/WC Rooms (Ensuites)
- Formal Entry
- Lounge/Sitting Room
- Family/Meals
- Quiet Room
- Kitchen/Pantry
- Alternative Sitting (optional)
- Disposal/Dirty Utility/Dirty Linen Room
- Medication Store
- Laundry (personal clothing)
- Clean Linen Store
- Case Storage
- General Storage
- Cleaner's Store
- Corridors/Circulation Spaces
- Fire Hose Reel Cabinets (concealed)
- Plant Rooms (as required)
- Telephone for Residents use
- Staff/Visitors Toilet (disabled type)
- Lockable storage for medications in:
 - Residents room (if Resident responsible for own medication)
 - A locked cupboard within a locked room (for medication controlled by staff).

Central Facilities:

- Quiet Room
- Administration
- Staff Toilets/Shower/Lockers
- Staff Dining/Lounge Room
- Storage (as appropriate)
- Laundry (central, as determined by operational policy)
- Soiled Linen Pick-up
- Clean Linen Delivery

- Bathroom
- Visitors' Toilet (disabled type)
- Cleaners Store
- Corridors with Sitting Nooks (for resident resting)
- Amenities Room(s) (optional, for large functions)
- Pantry (optional)
- Production Kitchen (and associated spaces)
- Enclosed Walkways (optional, but highly desirable for security reasons)
- Fire Hose Reel Cabinets (concealed)
- Plant Rooms (as required)
- Service Delivery Point.

Other External Considerations:

- Carport (for covered set-down)
- Pathways
- Roadways
- Rubbish Bin Enclosures/Garbage Pickup and bin wash area
- Letterboxes (one per house)
- Landscaping (resident accessible, with non toxic plants)
- Lighting (for resident access and security)
- Fencing (only where required, and open type preferred)
- External Seating
- Fly Screening
- Pergolas (for external sitting)
- Clothes Drying Areas
- Gardeners Store
- Verandas (optional, for "sitting out")
- Service Delivery Courts (as required, separate from resident areas)
- Fire Brigade Access/Hardstanding.

16.2 Common Oversights

The following are a number of common oversights:

- The use of ramps is to be minimised, but where they exist, they are to be designed to the Building Code of Australia (NCC).
- Door thresholds to the outside to be level with external paving. Bottom tracks of sliding doors to be flush with finished floor levels. Internal ramping of floors up to the sliding door track is not acceptable.
- Sill heights to external windows are to be no greater than 750mm above finished floor level to guarantee views to the outside when the resident is in the sitting position. (less than 600mm not recommended) This does not apply to ensuites, staff or service areas.

- Toilet seats should be of the rigid type to provide support.
- Corner guards and low-level wall and door protection should be provided wherever possible to prevent building damage.
- Non slip floor finishes are to be proven non-slip, even when wet.
- Transitions between different floor finishes to be fitted with appropriate diminishing strips or levels made the same. If the levels are different, and the selected floor colours are similar, the transition detail shall be a contrast colour to enable sight impaired residents to register the difference in levels.
- Door handles to be appropriate for the disabled. Refer AS1428.1 and The Independent Living Centre can advise.
- Sign posting to be kept to a minimum.
- Protruding features to be eliminated to prevent resident or staff injury.
- Acoustic privacy to be considered when locating and designing shared ensuites, day rooms, plant rooms and other spaces where acoustic isolation might be considered appropriate.
- When using sweep fans for cooling, ceiling heights should be dimensioned accordingly e.g. 2700mm recommended. This ensures that the blades of the fan are a minimum of 2400mm above the floor.
- The height above finished floor level of all light, fan, strip heater switches, GPOs, door handles, etc. should be between 900mm and 1100mm (1000mm preferred), in accordance with AS 1428.1.
- External paving shall be such that residents experiencing ambulatory problems are not inconvenienced or put at risk i.e. brick type paving to be flat and even, not raised cobblestone type. Broom finished concrete paving is an acceptable alternative.
- The leading edge of the 'tread' of steps (where provided) shall be in a contrast colour, to enable the sight impaired to register the steps.

Appendix 1 – Approval to occupy inspection

1. General

The Approval to Occupy Inspection as carried out by the licensing and Accreditation Regulatory Unit (LARU) of the Department of Health is a random audit of the facility/area. It is the Licence Holders and/or their representative's responsibility to do due diligence to ensure that the facility/area complies with Private Hospital Guidelines, Building Code of Australia and all relevant Australian Standards and is fit for intended function/use.

Glossary of terms

Architect means an individual registered architect or licensed architectural corporation that are currently registered with the Architects Board of Western Australia.

Building Surveyor a surveyor who is registered as a surveyor contractor under the *Building Services Registration Act 2011*

Certification means certification of the design and installation by the Engineer and certification of the installation by the installation contractor or specialist sub-contractor.

Date of Occupation means the date nominated by the 'Licence Holder' that the facility/area has been fully commissioned (both building commissioning and clinical commissioning) and is the day the service will commence.

DOH means Department of Health.

Engineer means an engineer as defined within the Engineering Services Health Facility Guidelines for Western Australia.

Hydraulic Designer means a designer with relevant AHSCA membership.

LARU means Licensing and Accreditation Regulatory Unit of the Department of Health.

Practical Completion means when all works are complete, except for any defects or omissions that do not prevent the building from being used for its intended purpose. The building is handed over to the owner at practical completion.

Shall means that the referenced item is mandatory.

Should means that the stated requirement is recommended, but is not mandatory.

Submitted design(s) mean the plans and specifications submitted to LARU at Approval to Construct and modified to incorporate all agreed Approval to Construct Mandatory Items. Submitted design(s) shall include any approved variations submitted after approval was granted.

The following issues shall be addressed prior to the Health Department of Western Australia Approval to Occupy Inspection.

- 1.1 An Approval to Occupy Inspection will not be conducted by LARU until all components of the works have been certified as having reached "Practical Completion" and the facility/area is completed in accordance with documentation and plans approved by LARU at Approval in Principle and Approval to Construct.

The certifications must be completed by the Architect and all Engineering Consultants and Contractors, and full services commissioning and certification data, as specified herein, must be available on site on the day of inspection and retained on site whilst the facility is licensed.

- 1.2 The facility/area shall prior to the Approval to Occupy Inspection be fully commissioned and compliant with all relevant standards for patient, staff or intended function.
- 1.3 Clinical commissioning –includes all furniture and equipment in situ:
 - 1.3.1 Consumables (medical and non-medical),
 - 1.3.2 Cleaning and environmental testing of sterile critical areas, and
 - 1.3.3 Staff training in emergency responses and use of medical equipment to be completed.
- 1.4 The 'Declaration for Approval to Occupy Inspection' form shall be completed and returned to LARU two (2) weeks prior to the Approval to Occupy Inspection.

2. Practical Completion

- 2.1 The works shall have reached "Practical Completion", and shall have been certified as such by the Architect and Engineering Consultants.

Note: The 'Practical Completion' date is not the same as the 'Date of Occupation'
- 2.2 The Architects and Engineers certification of practical completion and the registered building surveyors certification of construction compliance (BA17) or the certificate of building compliance (BA18) as required by the *West Australian Building Act 2011* shall be submitted and made available at the Approval to Occupy Inspection.
- 2.3 The certifying statement(s) shall confirm that the design and completed works have been completed and comply (in the professional opinion of the certifier) with the statutory requirements of the various Government controlling agencies, with the Department of Health West Australia Private Hospital Guidelines, current Building Code of Australia and relevant Australian Standards, any relevant Fire Engineering Report, and with the mandatory items that were identified with the issue of the Approval in Principle and Approval to Construct.
- 2.4 A list of defects, omissions and outstanding items shall be available at the ATO inspection and these items shall be made evident during the inspection.

3. Clinical Commissioning

The facility/area shall have been clinically commissioned and made ready for patient, staff or intended function prior to the Approval to Occupy Inspection.

- 3.1 All medical consumables, equipment and furniture shall have been installed
- 3.2 A hospital clean shall have been carried out for the area(s) to be inspected.
- 3.3 Staff fire evacuation and emergency training shall have been completed.
- 3.4 All operational and clinical policies and rosters for the facility/area shall have been completed and on site.

- 3.5 Cleaning and environmental testing of operating suites, operating rooms, procedure rooms, CSD areas and similar shall be completed and results on site.
- 3.6 Staff orientation and equipment training to the facility/area shall be completed.
- 3.7 Clinical commissioning shall ensure that all builders materials, hoardings, security fencing and site facilities etc. have been removed from the site.

For operating and procedure rooms the licence holder shall submit prior to the Approval to Occupy Inspection:

- 3.8 A statement of the procedures to be performed in each operating and procedure room.
- 3.9 Documentation that specifies the Operational Procedures for cleaning and environmental testing of each operating and procedure room.

In addition to the above the following shall be made available at the Approval to Occupy Inspection:

- 3.10 The statement of function for the facility/area to be inspected.
- 3.11 Any infection control audits or report that may have been carried out for the facility/area.
- 3.12 Any occupational health and safety audits or reports that may have been carried out for the facility/area.

4. Structural and Civil Certification

A statement by the design structural engineer that certifies that the building has been built in compliance with Section 18 of the West Australian Health Facility Guidelines for Engineering Services. The civil engineer shall similarly submit a statement that the building complies with Section 10. Similar certifications shall also be provided by independent Structural and Civil reviewers of the submitted design(s).

5. System testing

All building systems (fire, mechanical, electrical, hydraulic, etc.) shall have been fully tested and be working as designed/documented (as approved by the DOH).

6. Engineering Design Certification

Refer attachment A.

Certified statements which confirm that the designed, documented and witnessed mechanical, electrical and hydraulic engineering systems comply (in the professional opinion of the Certifier) with the statutory requirements of the various Government controlling agencies (including the DOH) shall be provided to the DOH.

The statement shall be prepared by professional mechanical, electrical engineers and hydraulic designers. The professional mechanical or electrical engineer or hydraulic designer shall certify the design and all commissioning and test data complies with the DOH West Australian Health Facility Guidelines for Engineering Services, relevant Australian standards, relevant Fire Engineering Report(s), and the mandatory items that were established or implied with the issue of the 'Approval in Principle' and 'Approval to Construct', the DOH Guidelines and all other statutory requirements.

7. Engineering Installation Certification

Refer attachment B.

The installing contractors or specialist subcontractors or the mechanical, medical gas, electrical and hydraulic services shall certify that the installation and construction complies with DOH West Australian Health Facility Guidelines for Engineering Services, relevant Australian Standards, relevant Fire Engineering Report(s), and mandatory items that were established or implied with the issue of the “approval to construct”. Certification of compliance with the other controlling Statutory Authorities (Water Corporation, WorkSafe WA, etc) shall also be provided.

Engineering scope

The engineering services mentioned in clauses 5, 6 and 7 above include, but are not limited

7.1 Mechanical systems:

- 7.1.1 Air conditioning
- 7.1.2 Heating
- 7.1.3 Ventilation
- 7.1.4 Exhaust,
- 7.1.5 Special exhaust,
- 7.1.6 Chilled and heating hot water
- 7.1.7 Medical gases and medical vacuum (including alarm systems)
- 7.1.8 Air filtration
- 7.1.9 Air pressure differentials
- 7.1.10 sterilisers (typically steam),
- 7.1.11 steam generators (or similar systems)
- 7.1.12 Mechanical switchboards and controls.

Note that where evaporative coolers are used, a statement is required certifying that a system for sanitation for Legionella control has been tested and is operational. The procedure shall be described in the Maintenance Manual (refer Clause 25).

Commissioning of medical gases and suction services shall be in strict accordance with the procedure outlines in AS 2896. This testing shall be witnessed and certified by the Mechanical Engineer and witnessed by a senior hospital representative.

7.2 Electrical and communication systems:

- 7.2.1 High voltage installation
- 7.2.3 Vital power supplies,
- 7.2.4 Earthing
- 7.2.5 Switchboards
- 7.2.6 Discrimination and cascading
- 7.2.7 Sub-mains and sub-circuit cabling,
- 7.2.8 Internal and external lighting,
- 7.2.9 Lighting for clinical observation,
- 7.2.10 Emergency evacuation lighting,
- 7.2.11 RCD protection,
- 7.2.12 Body and cardiac protection,
- 7.2.13 Lightning protection systems
- 7.2.14 Structured cabling installation
- 7.2.15 Messaging Systems
- 7.2.16 Assistance call systems,
- 7.2.17 Fire detection and alarm systems, etc.

7.3 Hydraulic systems:

- 7.3.1 Fire hydrants, hose reels and sprinklers systems
- 7.3.2 Potable and non-potable cold and hot water reticulation systems
- 7.3.3 Backflow prevention systems
- 7.3.4 Water Softening and Reverse Osmosis Water Systems
- 7.3.5 Natural or LP gas systems
- 7.3.6 Sanitary Fixtures and Tapware
- 7.3.7 Hospital appliances such as flushing rim sinks, washer/disinfector, macerator, etc.
- 7.3.8 Siphonic or gravity stormwater systems
- 7.3.9 Gravity or pump sewer systems.
- 7.3.10 Industrial waste and drainage systems.

8. Mechanical Ventilation and Air Conditioning Systems

Specific written data shall be provided in tabulated form confirming commissioning figures for toilet and general exhaust, ventilation rates (supply and return air), supply air and outside air quantities. The following presentation style is required.

Measurement Location	Code Req't	Design	Actual	% of Design
eg: Shared resident toilet and shower	10/Ls.m2	45 L/s	47 L/s	104

The method of determination and calibration data shall also be provided to enable assessment of the appropriateness of measurement.

Cold DOP testing of absolute (HEPA) filters shall be conducted in accordance with AS 1132.9. HEPA filters shall also be certified in accordance with AS1807.6 or AS 1807.7 as appropriate, after initial installation.

Air flow patterns within, to and from Operating, Set-up, Cytotoxic and Isolation Rooms, and other critical infection control areas served by absolute filters, shall be verified by air flow tests. Air flow diagrams showing the direction of flow to and from these areas shall be provided.

9. Medical Gas Services

The specialist Medical Gases installation contractor shall certify in writing that they are experienced and competent installers as required by AS2896 “Medical Gas Systems Installation and Testing of Non Flammable Medical Gas Pipeline Systems” and the WA Health Facility Guidelines.

Commissioning of gas and suction services shall be in strict accordance with the procedures outlined in the Australian Standard AS2896. Tests shall be witnessed by the Mechanical Engineer and a senior medical representative of the Hospital. Flow test results of oxygen nitrous oxide, medical air and vacuum services shall be provided. Cross connection and purity tests shall be provided for each outlet. All test results shall be submitted in AS2896 format. Procedures for regular reliable ongoing replenishment and service of all systems and equipment shall be verified as appropriate.

10. Electrical systems

Specific written test data shall be provided for the electrical installation including the following:

- 10.1 Routine testing to AS 3194 of all switchboards,
- 10.2 Compliance with AS 3000 (such as earthing, RCD's and the like) and functional operation of the system.
- 10.3 Where the electrical system incorporates a customer owned HV supply, all testing and commissioning data shall be provided to the Australian Standards, statutory authorities requirements and any other regulatory requirements for the HV system shall be provided.

The O&M manuals shall include (as a minimum) the following:

- 10.4 Certifications of compliance to AS/NZS 3000 and all other mandatory standards.
- 10.5 All electrical test result required for compliance to AS/NZS 3000
- 10.6 Supply authority tickets
- 10.7 A copy of all circuit schedules
- 10.8 Shop drawings for all switchboards, generators, transfer switches and the like.
- 10.9 A copy of all single line diagrams (revved up to As-Constructed)
- 10.10 A copy of all electrical drawings (revved up to As-Constructed).

11. Emergency lighting systems

Emergency lighting systems shall be tested in accordance with AS 2293 and full test results in 'log book' format shall be provided.

Certifications shall be provided of compliance to AS/NZS 2293 and the Building Code of Australia.

12. Vital power supplies

Full commissioning data shall be provided for emergency diesel, UPS and any other vital power supplies. Full discharge test results shall be provided for all battery systems.

Certifications shall be provided that the whole of the installation complies with AS 3009.

13. Electromedical areas

All electromedical areas shall be tested by an approved testing and commissioning company qualified to undertake testing to AS 3003.

Full test results to AS 3003 shall be provided including a complete and certified check-list.

Certifications shall be provided that the whole of the installation complies with AS 3003.

14. Assistance call systems

Functional test results shall be provided for the patient and emergency assistance call system.

A check-list for each point shall be provided indicating the operating status at the time of testing.

15. Fire Detection and Alarm Systems

Fire Detection and Alarm Systems shall be tested in accordance with the Australian Standards and statutory requirements, and any Fire Engineering Reports (if applicable). Full test results shall be provided.

Certifications shall be provided that the whole of the installation complies with AS 1670.

16. Domestic hot water system and temperature

Hot water installation systems shall be tested in accordance with the Australian Standards and statutory requirements. Full pressure test results shall be provided.

Specific written data shall be provided in tabulated form confirming commissioning figures for all tempered water outlets and hot water heater to confirm commissioned exact water temperatures. The following presentation style is required.

Measurement Location	Design	Actual
eg: Level 1: Hand basin in room 1.02	45 °C	44.6 °C

A confirmation test certificate shall be provided including laboratory test result to proof that the hot water system is free of Legionella and within the limitations of the Australian Drinking water guideline. The procedure shall be described in the Maintenance Manual (refer Clause 25).

The testing requirements and sanitation procedures shall be covered in the Maintenance Manuals.

Cold water system

Cold water installation systems shall be tested in accordance with the Australian Standards and statutory requirements. Full pressure test results shall be provided.

A confirmation test certificate shall be provided including laboratory test result to proof that the cold water system is free of Legionella and within the limitations of the Australian Drinking water guideline. The procedure shall be described in the Maintenance Manual (refer Clause 25).

RO water systems

SAT shall be carried out and commissioning data shall be supplied to confirm that the system is fully operational and the provided RO water quality complies with AS 4187.

All other hydraulic systems (Including wet fire services)

All systems shall be tested in accordance with the relevant Australian Standards and statutory requirements. Full test results shall be provided.

17. Environmental tests

The cleanliness of Operating Suites, including Operating Rooms, Set-up Rooms, Sterile Stores, Angiography and Cardiac Catheterisation Rooms, any other room(s) in which such sterile procedures will be completed, and Central Sterile Department/Units (CSD) shall be verified by air flow checks and bacterial sampling conducted by an appropriately NATA certified professional. Before testing, the following are required:

- 17.1 All building and engineering works have been completed.
- 17.2 The ducting has been cleaned, absolute filters installed, Cold Dispersed Oil Particulate (DOP) tests satisfactorily completed and air flows verified.
- 17.3 The operating room/s have been thoroughly cleaned.

- 17.4 The plant has been running under normal operating conditions for 24 hours prior to the test.
- 17.5 There is no activity in the operating room/s/unit.
- 17.6 The room(s) shall be tested by:
- 17.1.1 Noting the direction of air movement using a smoke test.
 - 17.1.2 Performing counts of bacterial colony forming units in both the air and on surfaces.

This is to be repeated once to confirm that duplication of results is possible.

If the room(s) fail the tests, the Engineer (mechanical) shall be consulted to confirm air velocities and filter integrity. The tests shall be repeated once the criteria are met.

18. Steriliser tests

The results of commissioning and appropriate testing data shall be provided in accordance with A/NZS 4187 Reprocessing of Reusable medical devices in health service organisations. These include:

- 18.1 Validation program is performed to evaluate the reliability of a sterilisation process
- 18.2 Validation will demonstrate that a given sterilisation cycle in an identified steriliser will render a specified load sterile
- 18.3 Verification of satisfactory cycle check tests and daily leak rate tests.
- 18.4 Bowie-Dick type test (conforms to BS7720) where applicable.
- 18.5 Access to suppliers tests.
- 18.6 Calibration of gauges.

19. Washer/Disinfector tests

Washer/disinfector machines, including pan washers, instrument washers and anaesthetic tubing washers shall pass appropriate cycle and challenge tests for mechanical action and disinfecting activity where applicable, also artificial soil tests and thermocouple tests post installation where indicated. Foil and graphite tests for ultrasonic cleaners. The results of the validation tests shall be provided.

20. Anaesthetic equipment tests

Certification is required from a specialist anaesthetist that the facilities and equipment are in accordance with the Guidelines for Safe Anaesthetic Practice issued by the Faculty of Anaesthetists, Royal Australasian College of Surgeons, in particular:

- T1. Recommended Minimum Facilities in Safe Anaesthetic Practice in Operating Suites.
- P4. Guidelines for the Care of Patients Recovering From Anaesthesia in the Recovery Room.

21. Fire Safety

In addition to the fire alarm and detection system, emergency and exit lighting, and the fire fighting (hydraulic) services mentioned prior, certification of the following (where appropriate) shall be provided:

- 21.1 Integrity and completeness of fire and smoke barriers, ie. full compartment/isolated space separation as required, with penetrations fully sealed with a material capable of maintaining the fire/smoke resistance of the barrier, or protected by an approved device designed for the purpose. Fire and smoke barriers must extend from true floor to the underside of the roof/slab over, and a fire wall must be able to maintain its structural integrity in the event of a wall and roof collapse on one side. Appropriate fire resistant packing between the top of a fire wall and roof cladding must be installed in a way that provides a continuous seal.
- 21.2 Fire dampers (in mechanical ductwork) tested and operational.
- 21.3 Door closers (hydraulic or electro magnetic) on all fire and smoke doors being fully operational and closing speed adjusted for safe operation.
- 21.4 Door sequence closing devices operational (where double fire/ smoke doors are fitted).
- 21.5 Fire door certification plates fitted to all fire doors and frames which comply with AS 1905.1.
- 21.6 Appropriate and permanent smoke seals fitted to all smoke doors.
- 21.7 Appropriate fire extinguishers and fire blankets installed.
- 21.8 Appropriate signposting installed in accordance with the relevant codes.
- 21.9 Special fire suppression systems tested and operational.
- 21.10 Use of fire resistance rated plasterboard to a tested system (Fyrchek, Boral, etc.) for the construction of fire barriers.
- 21.11 Appropriate and unobstructed means of egress.
- 21.12 The installed floor coverings, window treatments and bedscreen curtains in compliance with section C1.10 (specification), fire hazard indices, of the Building Code of Australia.
- 21.13 The installation, completeness and operation of the early warning fire system and its integration with all other associated systems.

22. Fire Brigade Facilities

Confirmation of the successful outcome of the following fire systems tests shall be forwarded to the DOH:

- 22.1 Testing of heating, ventilation and air conditioning (HVAC) systems in relation to smoke control to ensure compliance with Section E2 of the BCA. These tests will involve the use of artificial smoke to assess the movement of smoke and gases produced by a fire, to the greatest extent possible, particularly as to:
 - 22.1.1 means of egress;
 - 22.1.2 exit passageways or other similar areas;
 - 22.1.3 operating suite; and
 - 22.1.4 nurseries, birthing suites, etc.
 - 22.1.5 time taken to activate alarms, fire and smoke doors to close, and for smoke evacuation.
- 22.2 Testing of hydrant flow and pressure in accordance with AS 2419.1 Section 7. Test results shall be provided.
- 22.3 Testing of hydrant hose reel flow and pressure in accordance with AS 2441.
- 22.4 Provision of appropriate access routes and hardstanding for fire trucks. Earlier discussions and agreement with the fire brigade as a requirement at the design stage is assumed.

Where a Direct Brigade Alarm (DBA) connection is required, the connection shall be approved by the fire brigade and operational at the time of the ATO.

Where a DBA connection is not implemented at the time of the ATO, details shall be provided of the measures or works required that will be implemented to address this issue. These measures or works required shall be implemented prior to ATO.

23. Security

A certified statement shall be provided that confirms successful testing of any special electronic security systems, where provided.

24. Furniture and Equipment

All furniture and equipment shall be installed prior to Approval to Occupy Inspection so that an evaluation can take place during the Approval to Occupy Inspection. Where this is not possible, a written description of the type and quantity of loose furniture and equipment, including size and spatial requirements, to be installed including its location shall be provided.

25. Other Certification Issues

Certification of successful testing of any other items or systems that have been installed and which have not had DOH approval, along with a description of the system, what is replaced, and why, shall be provided.

26. “As Constructed” Drawings

A full set of ‘As Constructed’ drawings (architectural, structural, interior design, landscaping and services) shall be available for perusal as required during the Approval to Occupy Inspection.

All documentation that is required shall be labelled, sorted and placed into appropriate sections in folders to allow LARU Consultants to access relevant information.

All of the above documentation shall be kept at the facility for future reference.

If there have been any changes to documentation after the ATC approved set, a separate set of drawings that have changes clearly highlighted in colour shall be available on the day of the inspection and these changes shall be made evident to the LARU inspection team at the start of the inspection.

Six A3 floor plans (needn’t be to scale) highlighting the areas to be inspected and with all rooms correctly labelled in accordance with installed signposting, shall be available for LARU use during the inspection.

27. BCA Compliance Report and Fire Engineering Report

The Final BCA Compliance Report and Final Fire Engineering Report shall be available for perusal as required during the Approval to Occupy Inspection. These documents shall also be kept on site at all times.

28. Consultant Availability

The Project Architect, Engineering design consultants, specialist sub-consultants, and/or appropriately skilled contract personnel, shall be available during the Approval to Occupy inspection to answer technical questions and assist DOH officers in the systems checking process.

If there have been any changes to the professional consultants that were listed in the contact list at the time of the AIP submission (AIP 2), LARU shall be notified in writing of this change together with a brief reason for the change prior to the ATO inspection.

29. Hospital Personnel Availability

The hospital/facility/area personnel who have been involved in the design, planning and commissioning of the hospital/facility/area and the senior staff who will be responsible for the day to day management/running of the hospital/facility/area shall be available during the Approval to Occupy Inspection to answer technical questions and assist DOH officers in the systems checking process.

30. Maintenance Manual

Proof shall be provided that a manual exists which instructs the building proprietor on the maintenance requirements of the engineering systems and all equipment (including air conditioning plant, autoclaves, sterilisers and washer disinfectors, catering equipment, other plant, etc.). Availability of equipment manuals for operators and maintenance staff shall be confirmed.

Attachment A

Typical Consultant's Certification Letter

Add other Services where relevant

**Re: Anywhere Private Hospital
Electrical/Mechanical/Medical Gases/Hydraulic Services**

We advise that the electrical/mechanical/hydraulic services, documented for the....., have been effectively completed.

All engineering services have been tested and found to be working as designed.

To our knowledge the electrical/mechanical/medical gases/hydraulic/fire services installation, testing and commissioning complies with the contract documents and the Health Department of WA West Australian Health Facility Guidelines for Engineering Services, Australian Standards and the mandatory items that were established or implied with the issue of the 'Approval in Principle' and 'Approval to Construct'.

- Medical Gases cross connection and purity tests for each outlet have been witnessed by a senior hospital medical representative (medical gases only).

Attachment B

Typical installer's certification

Certification is required for each relevant service.

**Re: Anywhere Private Hospital
Electrical/Mechanical/Medical Gases/Hydraulic/Fire/Electromedical Services**

We advise that the electrical/mechanical/hydraulic services, installation for the....., have been effectively completed.

All engineering services have been tested and found to be working as designed.

To our knowledge the electrical/mechanical/medical gases/hydraulic/fire services installation, testing and commissioning complies with the contract documents and the Health Department of WA, West Australian Health Facility Guidelines for Engineering Services, Australian Standards and the mandatory items that were established or implied with the issue of the 'Approval in Principle' and 'Approval to Construct'.

Appendix 2 – Legionnaires’ Disease

1. Air handling systems and associated water cooling systems contamination by legionella

Design, installation, commissioning and maintenance including documentation and records of air handling systems and associated water cooling systems are to fully comply with Australian Standard 3666 “Air Handling and Water Systems of Buildings – Microbial Control”.

2. Water storage and distribution systems contamination by legionella

Water is supplied by the Water Authority of WA in a potable condition to health specifications. Every attempt should be made to preserve the quality of the supply.

Hot water should be stored and operated at a temperature not dropping below 60°C.

A maintenance program of regular de sludging should be implemented for any hot water storage vessel where stagnation and stratification in the lower levels of the tank may occur.

Water sampling for the culture of Legionella is not warranted for general hospital areas provided that the maintenance program is strictly adhered to.

Wards with concentrations of renal transplant, oncology and other immuno compromised patients are considered to be ‘high risk’ wards. The following additional advice is given for these situations:

- inspection of water distribution systems of the above wards to locate areas of flow stagnation and to plan for their early removal, (Monthly)
- drain sediment from calorifiers as necessitated by water quality, (Monthly)
- remove all shower heads and clean out accumulated sediment and scale, (Monthly)
- remove aerators from taps
- check all taps for natural rubber washers acid ‘O’ rings and replace with synthetic products
- check all thermostatic mixing valves for natural rubber components and replace with synthetic products. Regularly clean and service these valves, (Quarterly)
- showers and taps that are not frequently used should be flushed through weekly
- ensure water treatment plant, if installed, is checked regularly and is operating efficiently.

If gross contamination is detected, control may be achieved by cleaning of components, attention to water temperature, and/or disinfection, and/or other engineering factors. Discussion of the circumstances is advised.

2.1 Heated Spa Pool

Re-circulated water spa pools are not appropriate for Health Care Facilities. Fan blower type spas shall be used. Spa pools shall be regularly maintained in accordance with AS 2610.1.

2.2 Chemical Water Systems

Cold water storage and feed tanks associated with potable and non potable (fire sprinkler etc.) systems shall be separated (and identified) and regularly inspected for cleanliness. They shall be located in a shaded area to minimise solar heating. Fly wire shall be fitted to overflow and vent pipes to protect against insects and vermin.

This document can be made available in alternative formats on request for a person with disability.

Produced by the Licensing and Accreditation Regulatory Unit
© Department of Health 2017

Copyright to this material is vested in the State of Western Australia unless otherwise indicated. Apart from any fair dealing for the purposes of private study, research, criticism or review, as permitted under the provisions of the *Copyright Act 1968*, no part may be reproduced or re-used for any purposes whatsoever without written permission of the State of Western Australia.